Research Asistants:

Burcu Gökçal

Demet Çakır

2021-2022 FALL SEMESTER

FUEL CELLS

1. INTRODUCTION

Hydrogen was the first element formed after Big Bang and is still the most common element in Universe. It is a colourless and odourless gas, has a very low density and can be dangerously flammable.

Human beings are becoming aware that their thirst for energy and for burning fossil fuels to satisfy it, is not only polluting their only home, but almost certainly causing its atmosphere to become significantly warmer. Because of this global warming, a way of trapping energy from Sun and converting it directly into electricity have been investigated. The materials with which electricity can be used to break pure water into hydrogen and oxygen by electrolysis have been produced. Energy can be stored in hydrogen until needed, because hydrogen is so easily oxidized to water. This energy need not to be released mostly as heat, with a flash and a bang. The scientists and engineers are enable rapid and controlled reaction of hydrogen and oxygen to produce electricity at efficiency higher than that can be achieved using any other device. Because of the fact that in a hydrogen fuel cell the only produced material is water, it would be the supply of energy in the future. The probable cycle of energy production with fuel cell is shown in Figure 1.1.¹

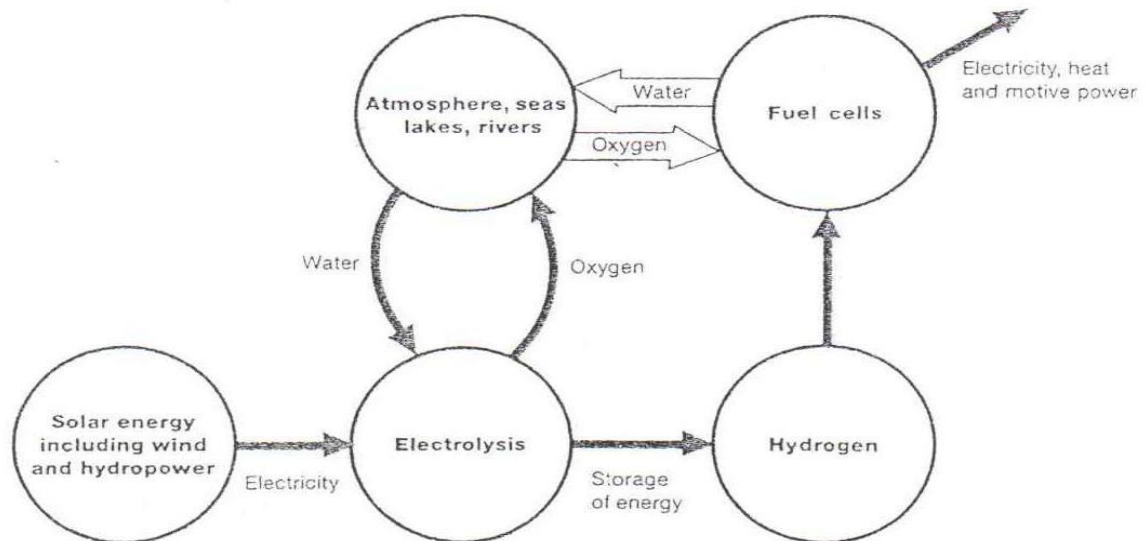

Figure 1.1. The probable cycle of energy production with fuel cell ¹

2. THEORY

Fuel cell is generally used with a solar cell and an electrolysis unit for breaking up water into hydrogen and oxygen and for producing electricity economically. To be able to comprehend the whole system, Solar Cell, Electrolysis Unit and Fuel Cell parts should be investigated individually. An example of the usage of the whole system is shown in Figure 2.1.

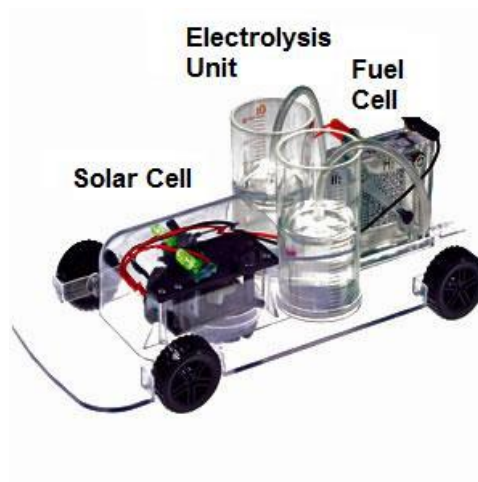

Figure 2.1. Fuel Cell Car Kit

2.1. Solar Cells

The sun provides with around 1000 Wm^{-2} on a sunny day and $50\text{-}200 \text{ Wm}^{-2}$ on a cloudy day, in temperate latitudes. If a building is correctly positioned and designed and also appropriate

materials are used for walls, window and roofs, the need for internal heating can be drastically cut.

A solar cell is a device that converts the energy of sunlight directly into electricity by the photovoltaic effect. Sometimes the term “solar cell” is reserved for devices intended specifically to capture energy from sunlight such as solar panels and solar cells, while the term “photovoltaic cell” is used when the light source is unspecified .

By 1949, the behavior of semiconductors was well known and at about the same time, the first silicon solar cell was developed. (The conductivity properties of silicon and the reasons for preferring of it at the design of solar cells are explained in Section 2.1.1). Today, solar cells are commonplace, powering tiny calculators and large scale electricity generating plants.¹

2.1.1. Conductors and Semiconductors

Silicon is an intrinsic semiconductor. This means that at normal temperatures it does not conduct very well because very few of its electrons are in the “conduction band”. By comparison a metal has an occupied “conduction band” where electrons are free to conduct. They are no longer bound to their parent atoms but form a “sea” of electrons in the conduction band which drift towards the positive terminal under the influence of an applied electric field. At higher temperatures some of the electrons in silicon can gain enough thermal energy and to “jump” the energy gap from where they are (valence band) and get into the conduction band. With more electrons in the conduction band the semiconductor now has a higher conductivity (lower resistivity). But even at higher temperatures silicon does not conduct very well. However, it is possible to “dope” intrinsic semiconductors and improve their conductivity markedly and turn them into what are called extrinsic semiconductors.²

2.1.2. Improving Conductivity of Silicon

The four electrons in the outer shell of silicon (valence electrons) are used to bond it to its neighbouring silicon atoms. Small number of foreign atoms with five outer electrons, such as atoms of arsenic or phosphorus can fit into the silicon lattice quite comfortably. But only four of their valence electrons are needed for bonding. The fifth electron is not required for bonding. Instead it sits in the conduction band where it is free to move and conducts is an electric field is applied. This addition of foreign atoms is called “doping”.

For each foreign atom, there is an extra free electron in conduction band which boosts the conductivity of silicon greatly. Silicon doped like this is termed “n-type” silicon as it has extra negative charge carriers. Typically there is only one foreign atom for 10^4 - 10^7 silicon atoms.^{1,3}

There is an alternative method: Using a trivalent atom, such as boron, offers only three electrons for bonding. This leaves a “hole” in the valance band. Because a “hole” is a lack of negative charge, it acts as a positive charge carrier which moves through the valance band as valance electrons “drop into the hole” and another hole appears. The doping produces p-type silicon, so called because of the extra positive charge carriers.⁴

2.1.3. Semiconductor Diodes- “p-n junctions”

Solar cells and semiconductor diodes are produced if p-type and n-type silicon are diffused together. At the junction, the free electrons in the n-type are attracted to the “holes” in the “p-type” silicon. They cross the junction and fall into the “holes”. The n- type silicon now becomes positive in the vicinity of the junction as it has lost electrons to the p-type (which becomes negative). As the charge difference builds up there is a potential barrier which prevents further diffusion of charge (by repulsion). The area where there are no longer any free charge carriers is called the depletion layer. The schematic diagram of p-n junction with depletion layer is shown in Figure 2.2.⁴

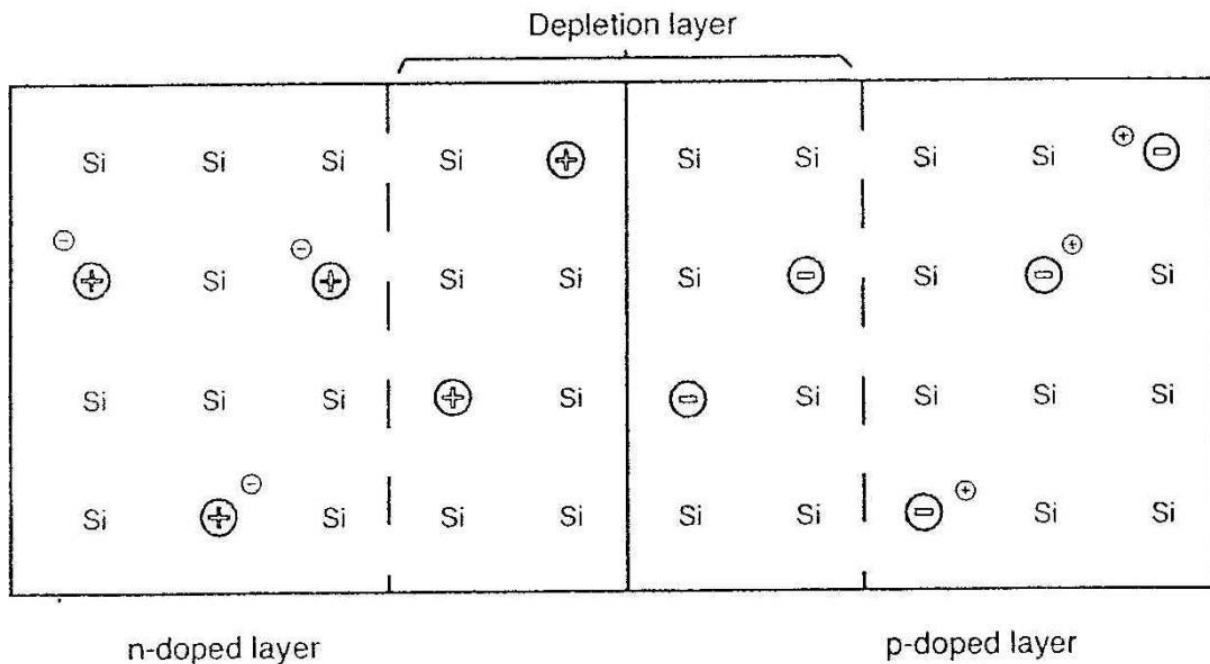

Figure 2.2. P-n junction with depletion layer ⁴

2.1.4. Working Principle of Solar Cell

Solar cells are typically doped silicon devices which convert light energy directly into electricity.

They are specially designed diodes where charge flow is affected by light. Photons of light hitting the solar cell are absorbed by electrons. This promotes the electrons into the conduction band and leaves a positive “hole” behind the valance band. The electric field across the “depletion layer” causes the negative electrons to drift into the n-type material while the holes are attracted into the p-type. This is how the n-type silicon (beyond the depletion layer) becomes negative and p-type becomes positive and a positive doped now exists across the solar cell. The cell can generate about 0.5-0.6 volts which will drive a current through an external circuit.

Semiconductors like silicon have a high refractive index. This means they are highly reflective. Less light is reflected and more is transmitted if the refractive indices of the two materials at the boundary are close in value. An anti-reflective coating is added to the top surface of a solar cell, this has a refractive index between that air and silicon, so that less light is reflected at the boundary. This makes the solar cell appear blue, as it is the blue end of the spectrum which is still reflected greatly (the refractive index of the coating for blue light is still quite different from the refractive index of air). The effect is to increase the amount of light transmitted into the silicon by 30% and it is the energy in the light which creates the “electron-hole” pairs.^{2,4}

If several solar cells are connected in series the total voltage is the sum of the individual voltages and the current remains constant. Connected in parallel their overall voltage remains equal to their individual voltage, but the total current is the sum of the partial currents. In reality keeping the current low is preferred, as this minimizes losses due to internal resistance and within the cables.

2.2. Electrolysis Unit

2.2.1. Hydrogen with Water

The obvious source of hydrogen is water. In the very early years of our planet, high-energy UV light from the Sun could penetrate the primitive atmosphere, which contained very little or no oxygen and break up water. (The breaking up of a substance by light energy is called photolysis). It is probable that, long before plants evolved, some oxygen entered the atmosphere through photolysis of water.

Many attempts have been made, using often complex catalytic systems to produce unmixed hydrogen and oxygen in large quantities from water by direct photolysis. None have so far been successful.

Hydrogen can be obtained from water by reaction with very reactive metals such as sodium and calcium; but such a method is impossibly expensive for large quantities. In industry, hydrogen is obtained in large quantities (for example the synthesis of ammonia by the Haber process) from catalyzed reactions involving steam and natural gas, or as a by-product from petroleum refining. Another source used to be the reaction of steam with white hot carbon (as coke). Hydrogen is also a co-product in the manufacture of chlorine and sodium hydroxide solution from the brine (saturated aqueous sodium chloride) by electrolysis.³

All the industrial methods involve fossil fuels or the use of electricity. If hydrogen is to be used for storing energy which can be released in a controlled way by a fuel cell, it makes sense to produce the hydrogen by a method which uses up the least pollutant waste. Such a method is electrolysis, using solar energy trapped and converted into electrical energy by photovoltaic cells.

2.2.2. Electrolysis: Breaking up Water

The meaning of the word electrolysis is “breaking-up by electricity”. An electric current is used to force chemical changes to occur in a substance; electric energy is converted into chemical energy. This is the exact opposite of what happens in a battery or a fuel cell.

There are two classes of substances which conduct electricity well: Metals and electrolytes.

In metallic conduction, the electric current consists of a flow of electrons through the material. No chemical change occurs in the conductor. The conductor may get hot because of

its resistance to the current flow. (This effect is used in electric heaters and filament light bulbs).⁵

In electrolytic condition, current flows between two electrodes which are immersed in the electrolyte. The current is carried not by electrons; but by ions.

2.2.3. Conventional Electrolysis

For a flow of current to be possible through an electrolyte, ions must both be present in the electrolyte and able to move. This has meant that; until quite recently, the electrolyte must be a molten salt, or a salt, acid, or alkali in aqueous solution or a paste.^{1,3}

Because of the potential difference between electrodes caused by the external power supply, positively charged ions (**cations**) move towards the negative electrode, the **cathode**. Negatively charged ions (**anions**) move towards the positive electrode, the **anode**.⁴

The electrodes must be made of a substance which both conducts electricity and is –as far as possible- chemically inert, unless the electrode is involved in the desired reaction. The graphite form of carbon is often chosen as the electrode material in industrial electrolysis.

At the cathode, positive ions are discharged-i.e. their positive charge is neutralized as the ions gain electrons from the cathode. The gain of electrons is **reduction**. At a cathode, reduction always occurs. At the anode, negative ions are discharged by losing electrons. Loss of electrons is **oxidation** and at an anode, oxidation always occurs.³

Reduction and oxidation occur simultaneously and one is impossible without the other. Electrolysis is an example of a redox process. Unlike other chemical processes, however, in electrolysis the reduction and oxidation occur separately at different places- cathode and anode.

2.2.4. Water Electrolysis Using Solid Electrolyte Membranes

Pure water contains a very low concentration of ions and cannot be split up by conventional methods because of its low conductivity. In recent years, the use of solid electrolytes has been developed. This is because an effective water electrolyser must have the electrodes separated by a membrane which has to stop gases passing through it (otherwise an extremely dangerous, explosive mixture of hydrogen and oxygen will be formed) but must allow ions to pass through- otherwise the circuit is not completed. The electrodes and the solid electrolyte

membrane are in very close contact, with the membrane being as thin as possible to keep electrical resistance low.

The theoretical voltage necessary for splitting up water is 1.23 V. In practice, the cell voltage has to be higher than this for electrolysis to proceed. Good electrode design and fine tuning of catalysts can bring the operating voltage down to 1.7-1.9 V; the closer the operating voltage is to the theoretical decomposition voltage, the greater efficiency of the process and the less waste of energy.

There are two common electrolyzers used in electrolysis process: Alkaline Electrolyzers and Polymer Electrolyte Membrane (PEM) Electrolyzers.

Alkaline electrolyzers

A thin membrane of a composite ceramic material separates the two electrodes as shown in Figure 2.3.

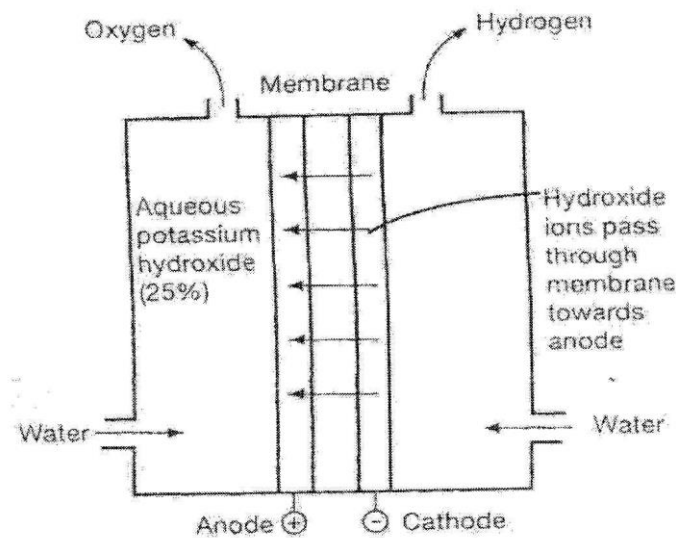

Figure 2.3. Schematic arrangement of an alkaline electrolyser ³

The electrolyte is aqueous potassium hydroxide (25% KOH in commercial electrolyzers) and the electrodes are based on nickel (nickel is not attacked by aqueous alkali).

At the anode, hydroxide ions give up their extra electrons and oxidized to oxygen and water. At the cathode, water is reduced to hydrogen gas and hydroxide ions. The circuit is completed

and charges inside the electrolyser are balanced by hydroxide ions passing through the membrane from the cathode side to the anode side.

The reactions occurring are shown in Table 2.1.

Table 2.1. Reactions occurring at the electrolyser

AT THE ANODE	AT THE CATHODE	OVERALL
$4\text{OH}^-(\text{aq}) \longrightarrow \text{O}_2(\text{g}) + 2\text{H}_2\text{O}(\text{l}) + 4\text{e}^-$	$4\text{H}_2\text{O}(\text{l}) + 4\text{e}^- \longrightarrow 2\text{H}_2(\text{g}) + 4\text{OH}^-(\text{aq})$	$2\text{H}_2\text{O}(\text{l}) \longrightarrow 2\text{H}_2(\text{g}) + \text{O}_2(\text{g})$

Polymer Electrolyte Membrane (PEM) Electrolysers

The operation of polymer electrolyte membrane (PEM) electrolysers is almost exactly the reverse of the way in which a PEM fuel cell works. The schematic diagram of PEM Electrolyser is shown in Figure 2.4.

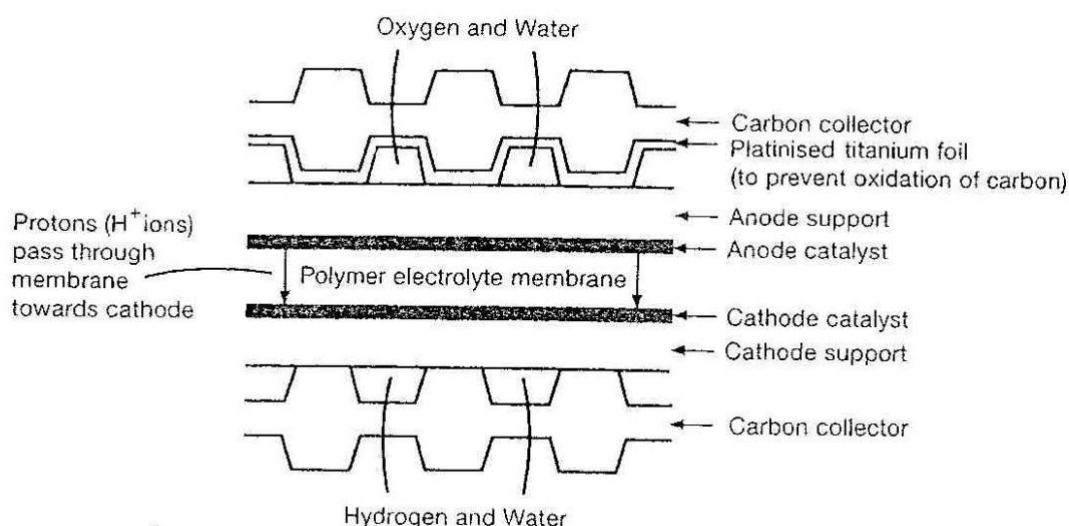

Figure 2.4. Diagram of a polymer electrolyte membrane water electrolyser ³

In typical electrolyser cell, the electrolyte is a thin membrane of Nafion (a sulphonated polymer similar to polytetrafluoroethene, Teflon). The membrane is only about 0.25 mm thick. The cathode has a porous carbon structure coated with very finely divided platinum; the anode has mixed ruthenium and iridium oxides as catalysts, again on porous carbon base. The anode support consists of titanium coated with platinum and the cathode support is carbon fibre. The carbon collectors carry current and contain channels so that water can reach the entire electrolyte and electrode surface.

In general deionised water is used as a hydrogen source. At the anode, water molecules are oxidized to oxygen and protons and electrons are released. At the cathode, protons are reduced, by gaining electrons to form hydrogen gas. The circuit is completed and charges balanced by protons passing through the membrane from the anode side to the cathode side. (This is the reverse process of the alkaline electrolyser).

The PEM electrolyser splits pure water into hydrogen and oxygen. Ideally, the electrical energy for this will in the future be provided from renewable, solar sources. The energy stored in the hydrogen produced during water electrolysis can be released by a fuel cell, using a membrane-electrode assembly very similar to that used in the electrolyser. And the only material product of the hydrogen fuel cell is pure water.

2.3. Fuel Cells

There are three common devices for releasing the stored energy: Internal combustion engines, batteries and fuel cells. They have some advantages and disadvantages according to their mechanism.

An internal combustion engine (ICE) mixes a fuel, usually consisting of a mixture of hydrocarbons with air; this mixture is then ignited by a spark (petrol engine) or by high compression/heating (Diesel). The expansion of the resulting hot gases provides power.

Electrolysis uses electrical energy to cause chemical reaction; batteries uses chemical reaction to produce electrical energy as a flow of electrons-an electric current-in an external circuit. The materials in the battery are consumed in the process. Energy is stored in the battery as chemical energy.

Any batteries used in e.g. a vehicle must be rechargeable, i.e. the chemical changes during the discharge must be reversed. Batteries must also, as far as possible, be light, occupy a relatively small volume and be capable of being recharged rapidly. Intensive research has led to much improvement in battery technology; but these three criteria are still a long way from being met. In addition, recharging batteries usually involves electricity generated in fossil fuel power stations (which is inefficient and also releases carbon dioxide and other more undesirable gases) and transmitted over long distances, which is wasteful. The normal vehicle battery is kept charged by using some of energy released by burning the fuel in the ICE.

The efficiency of fuel cells is much greater than ICEs and is not subject to the Carnot limitation. Because fuel cells usually have no moving parts they are silent and need little maintenance. They consume fuel at a rate strictly proportional to the load. If the fuel is hydrogen, no pollutants are formed; **the only product is water**. If fuel contains carbon, proportionally less CO₂ will be released into the atmosphere, because of higher efficiency of fuel cells.

The schematic diagram of the hydrogen fuel cell is shown in Figure 2.4.

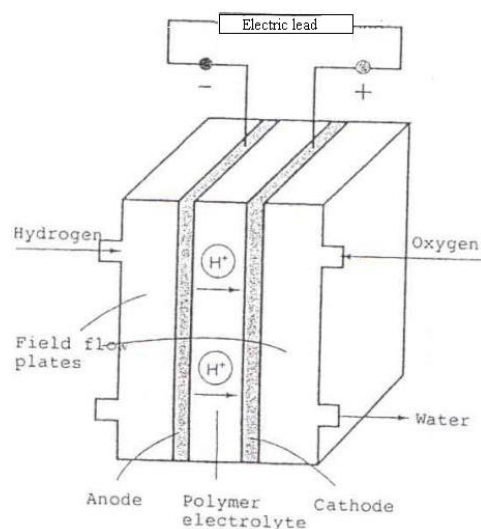

Figure 2.4. The arrangement in a typical hydrogen fuel cell ³

The basic cell consists of two porous carbon cloth electrodes bonded to a polymer electrolyte membrane. Outside the electrodes are flow field plates. These contain channels to ensure that the gases are in contact with the whole surface of the electrodes. They also serve to remove the water which is produced.

Oxidation (loss of electrons) occurs at the anode and reduction (gain of electrons) at the cathode. The fuel –in this case, hydrogen- is oxidized at the anode and releases electrons. These electrons can flow from the anode (which therefore becomes the negative terminal of the cell) around the external circuit to the cathode (which is therefore the positive terminal). Hydrogen ions flow through the polymer electrolyte membrane to the cathode to balance the charges.

A fuel cell can therefore supply a current in the same way as a storage cell (battery). However, unlike a battery, a fuel cell needs no recharging and its electrodes are unchanged.

The reactions occurring in the cell are given in Table 2.2.

Table 2.2. Reactions occurring at the fuel cell

AT THE ANODE	AT THE CATHODE	OVERALL
$2\text{H}_2(\text{g}) \longrightarrow 4\text{H}^+ + 4\text{e}^-$	$\text{O}_2(\text{g}) + 4\text{H}^+ + 4\text{e}^- \longrightarrow 2\text{H}_2\text{O} (\text{l})$	$2\text{H}_2(\text{g}) + \text{O}_2(\text{g}) \longrightarrow 2\text{H}_2\text{O} (\text{l})$

A hydrogen fuel cell has a maximum theoretical voltage 1.23 V (which is also the minimum voltage needed for the decomposition of water by electrolysis). In practice, because of losses caused by back-reaction, internal resistance and inefficient diffusion of the gases, the voltage obtained is 0.6-0.9, direct current (DC). Larger voltages are obtained by connecting cells in series, in stacks. Stacks connected in parallel provide larger currents. The maximum current which can be produced by a cell is proportional to the surface area of the electrodes. At the moment the maximum current density (current per unit surface area) obtainable is about 2 A cm^{-2} . Reaction at the electrodes would be far too slow without a catalyst, which for hydrogen fuel cells is usually platinum.

Because fuel cells can be made into stacks and modules, they can be used for all kinds of applications- from portable devices to large power stations. A general comparison of fuel cells according to their properties and applications are given in Table 2.3.

Table 2.3. Comparison of the various fuel cells

Fuel Cell	Electrolyte	Anode (Fuel)	Cathode (Gas)	Operating Temperature	Applications
<i>Alkaline Fuel Cell (AFC)</i>	Potassium hydroxide solution	Hydrogen	Oxygen	60-90 °C	Spacecraft Submarines
<i>Proton Exchange Membrane Fuel Cell (PEMFC)</i>	Proton-conductive polymer electrode	Hydrogen	Oxygen in air	60-90 °C	Transportation vehicles Stationary power plants Cogeneration plants Portable power supplies
<i>Direct Methanol Fuel Cell (DMFC)</i>	Proton-conductive polymer electrode	Methanol	Oxygen in air	90-120 °C	Transportation vehicles Portable power supplies
<i>Phosphoric Acid Fuel Cell (PAFC)</i>	Phosphoric acid	Hydrogen	Oxygen in air	200 °C	Stationary power plants Cogeneration plants
<i>Molten Carbonate Fuel Cell (MCFC)</i>	Molten alkaline carbonate	Hydrogen, methane or coal gas	Oxygen in air	650 °C	Stationary power plants Cogeneration plants
<i>Solid Oxide Fuel Cell (SOFC)</i>	Ceramic solid electrolyte	Hydrogen, natural gas or coal gas	Oxygen in air	800-1000 °C	Stationary power plants Cogeneration plants

The contribution to cell overvoltage can be minimized by; (i) finding better catalysts and increasing their surface area; (ii) good design of the structures of membrane-electrode assemblies and field flow plates; (iii) using highly conductive (low resistance) materials and contacts.

One way of reducing internal resistance is to make electrolyte membranes thinner- which decreases resistance- and to increase their conductivity.

The most recent developments in the fuel cells have concentrated on two main areas: automotive applications such as passenger vehicles and cars, and stationary power generators for home and business use where their ability to produce both heat and power (so called co-generation) gives an overall efficiency of around 80%. However there is a real possibility of fuel cells replacing batteries in consumer electronics as hydrogen storage mechanisms improve.

3. EXPERIMENTAL SECTION

3.1. Experimental Set Up

The general diagram of the fuel cells experimental apparatus is shown in the Figure 3.1.

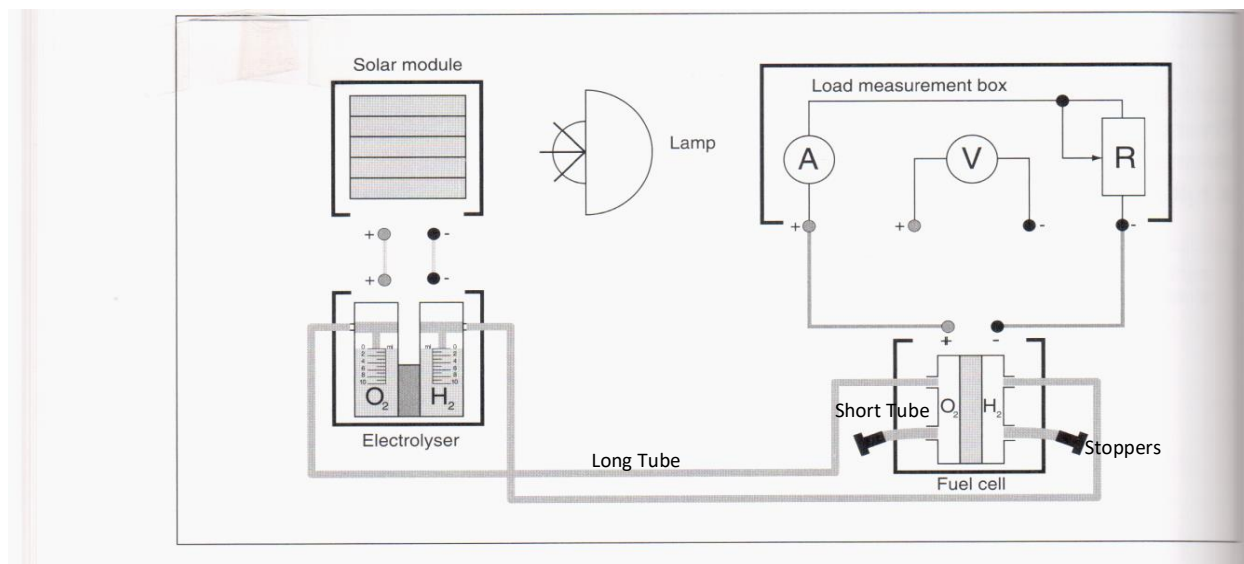

Figure 3.1. Diagram of the experimental apparatus ⁵

Apparatus Required:

- Solar module
- Electrolyser
- Fuel cell
- Load measurement box
- Connecting leads
- 2 long tubes
- 2 short tubes
- 2 tubing stoppers

Additional Components:

- Lamp, 100-150 Watt
- Distilled water (about 100 ml)
- 2 small test tubes (100 ml capacity)

3.2. Experimental Procedure

3.2.1. Safety

- Please follow the operating instructions.
- Wear protective goggles and keep ignition sources at a distance when experimenting.
- Solar module becomes hot.
- A full risk analysis must be undertaken before beginning any experiment.

3.2.2. Experiment 1: Characteristic curve of the electrolyser

Objective

To use the solar module to investigate how the current through the electrolyser varies with the voltage applied, and to find the minimum voltage at which electrolysis begins.

Procedure

- Assemble the appropriate components as shown in the fig. 3.2. , with a lamp, so that the current and the voltage through the electrolyser can be measured at the same time.
- All connections must be correctly made, with correct polarity. Check with your teacher before proceeding.

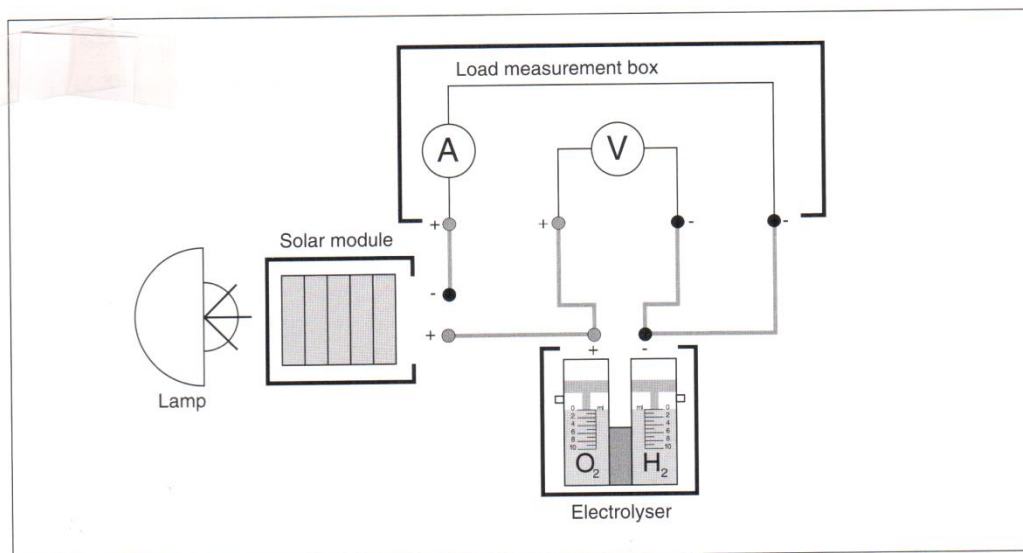

Figure.3.2. Experimental Set up for Experiment 1 ⁵

Results, records and evaluation

1. Draw a circuit diagram and explain its arrangement.
2. Construct a suitable results table for recording your data, either on paper or as a spreadsheet.
3. Plot the characteristic curve for the electrolyser (with current on the vertical axis), and find the minimum voltage at which electrolysis begins.
4. Comment on the shape of curve.
5. Evaluate the techniques used in your experiment; identify any difficulties you encountered and how they were overcome.
6. Suggest any ways in which the experiment procedure might be improved.

And please answer;

The theoretical minimum voltage required for the splitting of water is 1.23 V. How does this compare with voltage which you have found? If there is a difference between the two values, can you explain how the difference arises?

3.2.3. Experiment 2: Characteristic curve of the fuel cell

Objective

By using hydrogen and oxygen generated photovoltaically, to investigate how the current produced by the cell varies with the voltage.

Procedure

- Assemble the appropriate components as shown in the fig.3.1. , additional with the stoppers, with a lamp, and use the gases produced by the electrolyser to remove all air from the apparatus ('purging').
- All connections must be correctly made, with correct polarity. Check with your teacher before proceeding.
- The current to the electrolyser should be 200-300 mA. Pass gases through the entire system for 5 minutes, and then switch to $3\ \Omega$ for 3 minutes, then purge for 3 more minutes with the switch 'OPEN'.
- Then adjust the apparatus so that the current and voltage produced by the fuel cell can be measured at the same time, using gases stored in the electrolyser to power the cell.

- Investigate how the current and voltage vary as the value of the resistance load is altered. Start in the 'OPEN' position, and then decrease the resistance stepwise. For each resistance wait 30 s before noting the voltage and current. Take the measurements for 'LAMP' and 'MOTOR'.

Results, records and evaluation

1. Draw a circuit diagram and explain its arrangement.
2. Construct a suitable results table for recording your data, either on paper or as a spreadsheet.
3. Plot the characteristic curve (VI) for the fuel cell (with voltage on the vertical axis), and find the maximum voltage obtainable from the fuel cell. Place the lamp and motor on the curve.
4. Comment on the shape of curve.
5. Plot the power curve (PI) for the cell (with power in mW on the vertical axis). Place the lamp and motor on the curve.
6. Comment on the shape of curve.
7. Evaluate the techniques used in your experiment, identify any precautions taken, and describe any difficulties you encountered and how they were overcome.
8. Suggest any ways in which the experiment procedure might be improved.

And please answer;

The theoretical maximum voltage for a hydrogen fuel cell is 1.23 V. How does this compare with voltage which you have found? If there is a difference between the two values, can you explain how the difference arises?

3.2.3. Experiment 3: Investigating the fuel cells- which is the best; connected in series or in parallel?

Objective

To investigate the behavior of fuel cells connected in series and parallel.

Procedure

In order to use the fuel cells as a power source they must be provided with a supply of hydrogen and oxygen from the electrolyser. This may have been done for you in advance of the experimental session. Alternatively proceed as follows:

Figure 3.3. shows the schematic diagram for connection in series

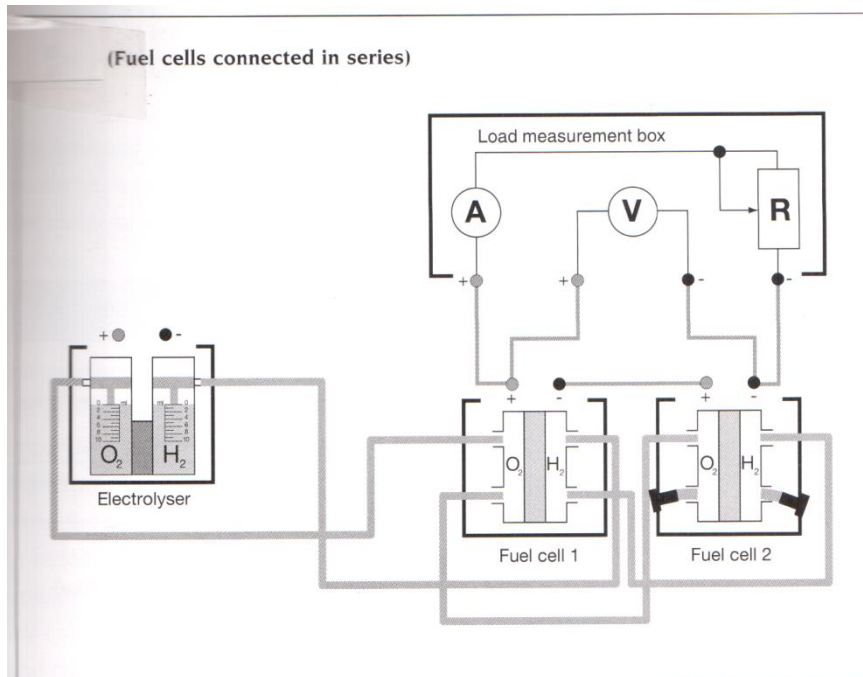

Figure.3.3. Schematic Diagram for Fuel Cells Connected in Series ⁵

- Set up the apparatus as shown in the Fig. 3.3. Check the polarity of the electrolyser.
- Check that the gas tubes between the electrolyser and fuel cells 1 and 2 are correctly connected.
- Adjust the rotary switch on the load measurement box to 'OPEN'.
- Make sure of the gas storage cylinders of the electrolyser are filled with distilled water up to 0 ml mark. Using the illuminated solar module, set a constant current to the electrolyser of between 200 and 300 mA. The solar module must be positioned towards the light source in such a way that gas production can be clearly observed.
- Purge the complete system (consisting of the electrolyser, fuel cells and tubes) for 10 min. with the gases produced. Then set the rotary switch on the load measurement box to 3Ω for 3 minutes. The ammeter of the load measurement box should now already shows a current. Purge the system again with the rotary switch in the 'OPEN' position for 5 minutes.
- Stop the power supply to the electrolyser for a short time and use the stoppers to close the two short tubes at the gas outlets of fuel cell 2.
- Reconnect the solar module to the electrolyser and store the gases in the gas store cylinders of the electrolyser. Interrupt the power supply when the hydrogen side of the electrolyser has reached 10 ml mark.

- Remove the connecting leads between the solar module and the electrolyser and use them to connect the voltmeter of the load measurement box to the fuel cell. You can now record the characteristic curve of the two fuel cells connected in series.
- Now construct your circuit as designed previously using the fuel cells in series as the voltage source (with outlets of the electrolyser supplying gas to the fuel cell) and check that the apparatus gives readings over a suitable range.
- Vary the value of the load resistor and investigate how the e.m.f and current vary as the value of the load resistor is changed. Also take measurements using the motor and lamp as loads.

Repeat your investigation for two fuel cells connected in parallel. Fig.3.4. shows the schematic diagram for connection in parallel.

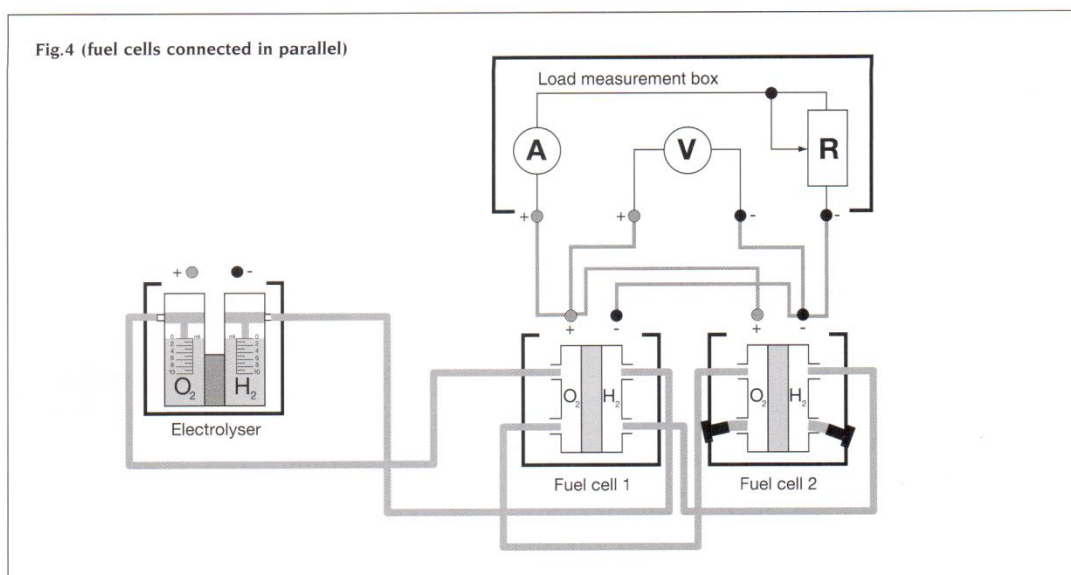

Figure.3.4. Schematic Diagram for Fuel Cells Connected in Parallel ⁵

Results, records and evaluation

1. Explain the experimental technique used obtain the data.
2. Device and complete a suitable results table to record your data, either on paper or on a computer spreadsheet.
3. Plot the characteristic curve for the fuel cells in series and for fuel cells in parallel.
4. Comment on the shape of the curve in comparison with the curve obtained from a single fuel cell in experiment 2. Comment also on the motor and lamp.

5. Comment on any problems you encountered during the experiment, any precautions taken to ensure accuracy and any changes you made to your original plan.
6. Finally evaluate the experimental technique you used and suggest any further improvements for the experiment.^{5,6}

NAME-SURNAME:

GROUP NO:

ASSISTANT:

DATE:

DATA SHEET

Experiment 1: Characteristic curve of the electrolyser

Voltage(V) (V)	Current(I) (A)	Distance(cm)

Experiment 2: Characteristic curve of the fuel cell

Resistance (R) (Ω)	Voltage (V) (V)	Current (I) (A)

***Faraday efficiency and energy efficiency for single fuel cell**

R=OPEN

$V_{t=0}$: mL

$V_{t=6 \text{ dk}}$: mL

R=3 Ohm

$V_{t=0}$: mL

$V_{t=3 \text{ dk}}$: mL

$I_{t=3 \text{ dk}}$: A

$V_{t=3 \text{ dk}}$: V

Experiment 3: Investigating the fuel cells- which is the best; connected in series or in parallel?

Fuel Cells in Series:

Resistance (R) (Ω)	Voltage (V) (V)	Current (I) (A)

Fuel Cells in Parallel:

Resistance (R) (Ω)	Voltage (V) (V)	Current (I) (mA)

Comparison of Lamp and Motor:

		SERIES		PARALLEL	
	Resistance (R) (Ω)	Voltage (V) (V)	Current (I) (A)	Voltage (V) (V)	Current (I) (A)
Lamp					
Motor					

NOMENCLATURE

- D: Distance (Centimeter, cm)
- I: Current (Ampere, A)
- R: Resistance (Ohm, Ω)
- V: Voltage (Volt, V)

4. REFERENCES

1. Physics through Hydrogen-Clean Energy for the Future (volume3)/ Averil Macdonald. 5rd edition 2006; Berlin heliocentric Energiesysteme GmbH, 2000.
2. Science through Hydrogen-Clean Energy for the Future (volume1)/ Averil Macdonald; Martyn Berry. 5rd edition 2007; Berlin heliocentric Energiesysteme GmbH, 2000-2007.
3. Chemistry through Hydrogen-Clean Energy for the Future (volume2)/ Averil Macdonald; Martyn Berry. 5rd edition 2007; Berlin heliocentric Energiesysteme GmbH, 2000-2007.
4. Energy through Hydrogen-Clean Research Notes/ Averil Macdonald; Martyn Berry. 5rd edition 2007; Berlin heliocentric Energiesysteme GmbH, 2000-2007.
5. Experiment Instructions for hydro-GeniusTM Professional, May 2000 model and later. 1st edition, 1 September 2000.
6. Operating Instructions for hydro-GeniusTM Professional, May 2000 model and later. 1st edition, 15 May 2000.