

3.5.02-00 Thermal and electrical conductivity of metals



What you can learn about ...

- Electrical conductivity
- Wiedmann-Franz law
- Lorenz number
- Diffusion
- Temperature gradient
- Heat transport
- Specific heat
- Four-point measurement

Principle:

The thermal conductivity of copper and aluminium is determined in a constant temperature gradient from the calorimetrically measured heat flow.

The electrical conductivity of copper and aluminium is determined, and the Wiedmann-Franz law is tested.

Tasks:

1. Determine the heat capacity of the calorimeter in a mixture experiment as a preliminary test. Measure the calefaction of water at a temperature of 0°C in a calorimeter due to the action of the ambient temperature as a function of time.
2. To begin with, establish a constant temperature gradient in a metal rod with the use of two heat reservoirs (boiling water and ice water) After removing the pieces of ice, measure the calefaction of the cold water as a function of time and determine the thermal conductivity of the metal rod.
3. Determine the electrical conductivity of copper and aluminium by recording a current-voltage characteristic line.
4. Test of the Wiedmann-Franz law.

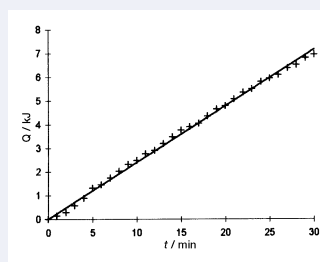

Diagram: Heat of surroundings over time.

What you need:

Calorimeter vessel, 500 ml	04401.10	1
Calor. vessel w. heat conduct. conn.	04518.10	1
Heat conductivity rod, Cu	04518.11	1
Heat conductivity rod, Al	04518.12	1
Magn. stirrer, mini, controlable	47334.93	1
Heat conductive paste, 50 g	03747.00	1
Gauze bag	04408.00	1
Rheostat, 10 Ω, 5.7 A	06110.02	1
Immers.heater, 300 W, 220-250 VDC/AC	05947.93	1
Temperature meter digital, 4-2	13617.93	1
Temperature probe, immers. type	11759.01	1
Surface temperature probe PT100	11759.02	2
Stopwatch, digital, 1/100 sec.	03071.01	1
Tripod base -PASS-	02002.55	1
Bench clamp -PASS-	02010.00	1
Support rod -PASS-, square, l = 630 mm	02027.55	1
Support rod -PASS-, square, l = 1000 mm	02028.55	1
Universal clamp	37715.00	4
Right angle clamp -PASS-	02040.55	6
Supporting block 1053105357 mm	02073.00	1
Glass beaker, short, 400 ml	36014.00	1

For the electrical conductivity you need:

Multitap transf., 14 VAC/12 VDC, 5 A	13533.93	1
Digital multimeter	07134.00	2
Universal measuring amplifier	13626.93	1
Connecting cord, l = 500 mm, red	07361.01	4
Connecting cord, l = 500 mm, blue	07361.04	4

Complete Equipment Set, Manual on CD-ROM included
Thermal and electrical conductivity of metals P2350200

Related topics

Electrical conductivity, Wiedmann-Franz law, Lorenz number, diffusion, temperature gradient, heat transport, specific heat, four-point measurement.

Principle

The thermal conductivity of copper and aluminium is determined in a constant temperature gradient from the calorimetrically measured heat flow.

The electrical conductivity of copper and aluminium is determined, and the Wiedmann-Franz law is tested.

Equipment

Calorimeter vessel, 500 ml	04401.10	1
Calor. vessel w. heat conduct. conn.	04518.10	1
Heat conductivity rod, Cu	04518.11	1
Heat conductivity rod, Al	04518.12	1
Magn. stirrer, mini, controlable	47334.93	1
Heat conductive paste, 50 g	03747.00	1
Gauze bag	04408.00	1
Rheostat, 10 Ω , 5.7 A	06110.02	1

Immers.heater, 300 W, 220-250 VDC/AC	05947.93	1
Temperature meter digital, 4-2	13617.93	1
Temperature probe, immers. type	11759.01	1
Surface temperature probe PT100	11759.02	2
Stopwatch, digital, 1/100 sec.	03071.01	1
Tripod base -PASS-	02002.55	1
Bench clamp -PASS-	02010.00	1
Support rod -PASS-, square, $l = 630$ mm	02027.55	1
Support rod -PASS-, square, $l = 1000$ mm	02028.55	1
Universal clamp	37715.00	4
Right angle clamp -PASS-	02040.55	6
Supporting block $105 \times 105 \times 57$ mm	02073.00	1
Glass beaker, short, 400 ml	36014.00	1
Multitap transf., 14 VAC/12 VDC, 5 A	13533.93	1
Digital multimeter	07134.00	2
Universal measuring amplifier	13626.93	1
Connecting cord, $l = 500$ mm, red	07361.01	4
Connecting cord, $l = 500$ mm, blue	07361.04	4

Tasks

1. Determine the heat capacity of the calorimeter in a mixture experiment as a preliminary test. Measure the calefaction of water at a temperature of 0°C in a calorimeter due to the action of the ambient temperature as a function of time.
2. To begin with, establish a constant temperature gradient in a metal rod with the use of two heat reservoirs (boiling water and ice water) After removing the pieces of ice, measure the calefaction of the cold water as a function of time and determine the thermal conductivity of the metal rod.
3. Determine the electrical conductivity of copper and aluminium by recording a current-voltage characteristic line.
4. Test of the Wiedmann-Franz law.

Set-up and procedure

1. Measurement of the heat capacity of the lower calorimeter
 - Weigh the calorimeter at room temperature.
 - Measure and record the room temperature and the temperature of the preheated water provided.
 - After filling the calorimeter with hot water, determine the mixing temperature in the calorimeter.
 - Reweigh the calorimeter to determine the mass of the water that it contains.
 - Calculate the heat capacity of the calorimeter.
 - Determine the influence of the heat of the surroundings on the calefaction of the water (0°C without pieces of ice) by measuring the temperature change in a 30-minute period.
2. Determination of the thermal conductivity
 - Perform the experimental set-up according to Fig. 1.
 - Weigh the empty, lower calorimeter.
 - Insert the insulated end of the metal rod into the upper calorimeter vessel. To improve the heat transfer, cover the end of the metal rod with heat-conduction paste.
 - Attach the metal rod to the support stand in such a manner that the lower calorimeter can be withdrawn from beneath it.

Fig. 1a: Experimental set-up for thermal conductivity.



- The height of the lower calorimeter can be changed with the aid of the supporting block. When doing so, care must be taken to ensure that the non-insulated end of the rod remains completely immersed in the cold water during the experiment.
 - The surface temperature probe must be be positioned as close to the rod as possible.
 - The outermost indentations on the rod (separation: 31.5 cm) are used to measure the temperature difference in the rod. To improve the heat transfer between the rod and the surface probe, use heat-conduction paste.
 - Using an immersion heater, bring the water in the upper calorimeter to a boil, and keep it at this temperature.
 - Ensure that the upper calorimeter is well filled to avoid a drop in temperature due to contingent refilling with water.
 - Keep the water in the lower calorimeter at 0°C with the help of ice (in a gauze pouch).
 - The measurement can be begun when a constant temperature gradient has become established between the upper and lower surface probes, i.e. when no changes occur during the differential measurement.
 - At the onset of measurement, remove the ice from the lower calorimeter.
 - Measure and record the change in the differential temperature and the temperature of the water in the lower calorimeter for a period of 5 minutes.
- Weigh the water-filled calorimeter and determine the mass of the water. Settings of the temperature measuring device 4-2:
 - In the first display on the measuring device, the temperature of the lower calorimeter is displayed.
 - In the second display, the differential measurement between the upper and the lower surface probe is shown.
 - The thermal conductivity of different metals can be determined from the measuring results.
3. Measurement of the electrical conductivity.
- Perform the experimental set-up according to the circuit diagram in Fig. 2 (set-up in accordance with a 4-conductor measuring method).
 - Set the voltage on the variable transformer to 6 V.
 - The amplifier must be calibrated to 0 in a voltage-free state to avoid a collapse of the output voltage.
 - Select the amplifier settings as follows:

Input:	Low Drift
Amplification:	10^4
Time Constant:	0
 - Set the rheostat to its maximum value and slowly decrease the value during the experiment.
 - Read and note the values for current and voltage
 - The resistance, and thus the electrical conductivity, can be determined from the measured values.

Fig. 1b: Experimental set-up for electrical conductivity.

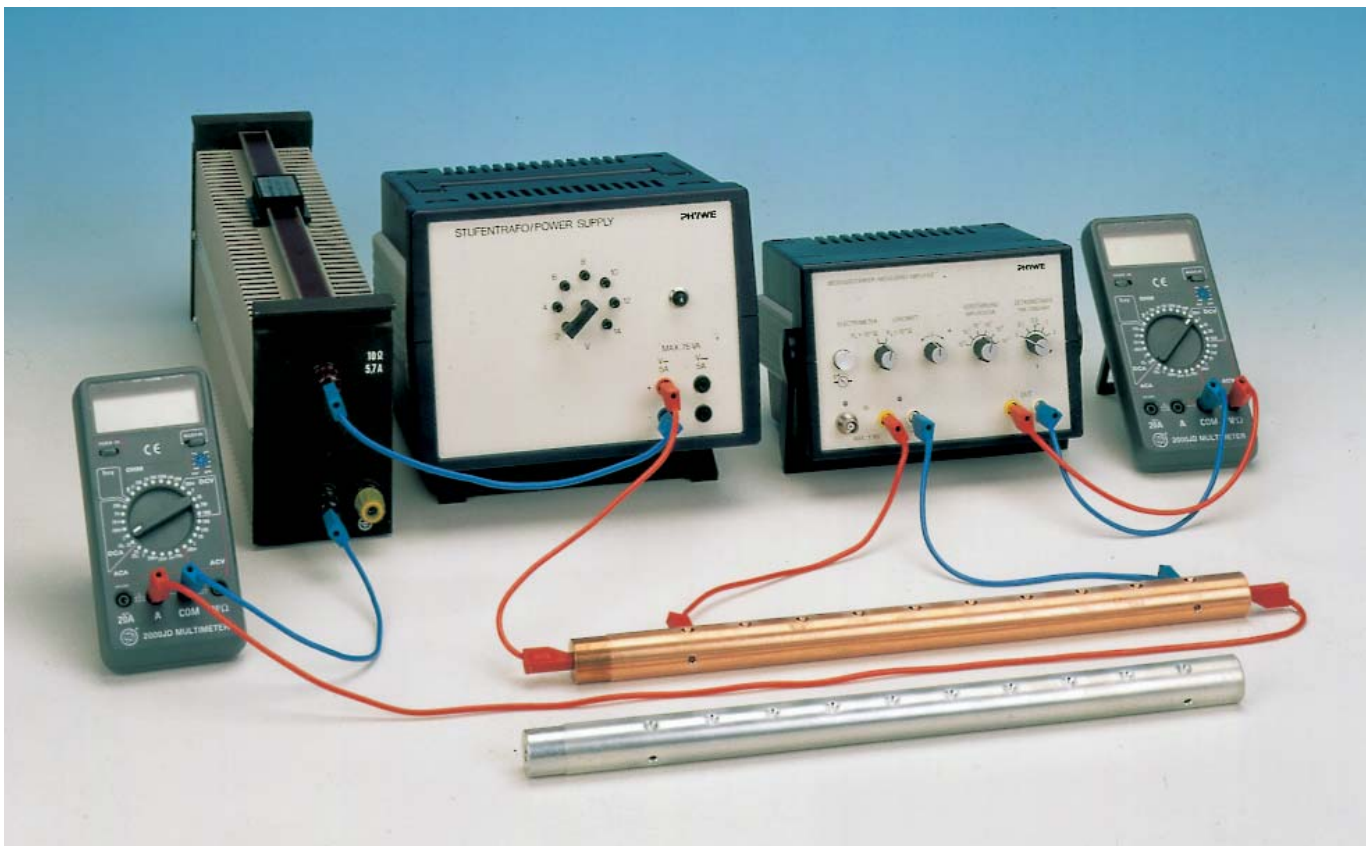

Fig. 2.

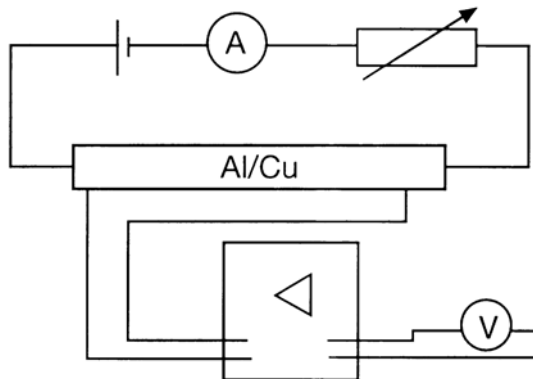
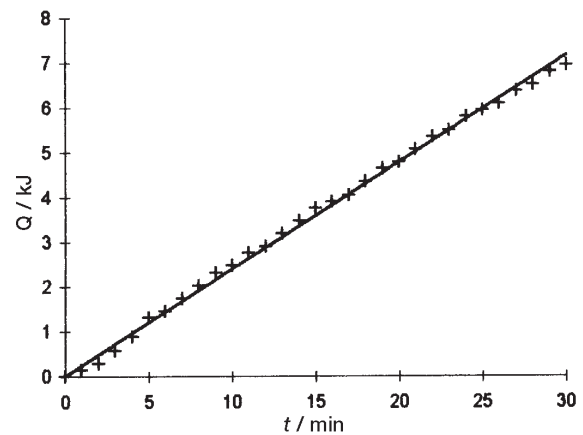

Fig. 3. Diagram: Heat of surroundings over time.



Theory and evaluation

If a temperature difference exists between different locations of a body, heat conduction occurs. In this experiment there is a one-dimensional temperature gradient along a rod. The quantity of heat dQ transported with time dt is a function of the cross-sectional area a and the temperature gradient $\delta T/\delta x$ perpendicular to the surface.

$$\frac{dQ}{dt} = -\lambda A \cdot \frac{\partial T}{\partial x} \quad (1)$$

λ is the heat conductivity of the substance.

The temperature distribution in a body is generally a function of location and time and is in accordance with the Boltzmann transport equation

$$\frac{\partial T}{\partial t} = \frac{\lambda}{\rho \cdot c} \cdot \frac{\partial^2 T}{\partial x^2} \quad (2)$$

Where ρ is the density and c is the specific heat capacity of the substance.

After a time, a steady state

$$\frac{\partial T}{\partial x} = 0 \quad (3)$$

is achieved if the two ends of the metal rod having a length l are maintained at constant temperatures T_1 and T_2 , respectively, by two heat reservoirs.

Substituting equation (3) in equation (2), the following equation is obtained:

$$T(x) = \frac{T_2 - T_1}{l} \cdot x + T_1 \quad (4)$$

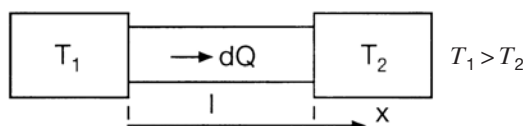

- The heat capacity of the calorimeter is obtained from results of the mixing experiment and the following formula:

$$C = c_W \cdot m_W \cdot \frac{\vartheta_W - \vartheta_M}{\vartheta_M - \vartheta_R} \quad (5)$$

- c_W = Specific heat capacity of water
- m_W = Mass of the water
- ϑ_W = Temperature of the hot water
- ϑ_M = Mixing temperature
- ϑ_R = Room temperature

The measurement supplies a value of approximately 78 J/K $\pm 25\%$. The large variations in the results are a result of the manner in which the experiment is performed and of the experimental set-up.

The addition of heat from the surroundings is calculated from the temperature increase (T of the cold water in the calorimeter).

$$\Delta Q = (c_W \cdot m_W + C) \cdot \Delta T \quad (6)$$

where $\Delta T = T - T_0$

T_0 = Temperature at time $t = 0$

- The heat energy supplied to the lower calorimeter can be calculated using Equation (6). The values and the change in the temperature difference on the metal rod are plotted as a function of time.

In the diagram illustrating the temperature difference, one can see that the temperature essentially remains constant. Consequently, equation 3 can be considered as having been satisfied. In order to calculate the heat energy transported by the metal rod according to Equation 1, the ambient heat fraction must be subtracted.

$$\frac{dQ_{\text{rod}}}{dt} = \frac{dQ_{\text{tot}}}{dt} - \frac{dQ_{\text{surr}}}{dt} \quad (7)$$

dQ/dt for the ambient heat can be calculated from the slope of the graph in Fig. 3. dQ/dt for the entire set-up can be calculated from the slope of the graph of Q over t in Figs. 4 and 5. With the values for the length of the rod ($\Delta x = 31.5$ cm), the

Fig. 4a: ΔT as function of time for aluminium.

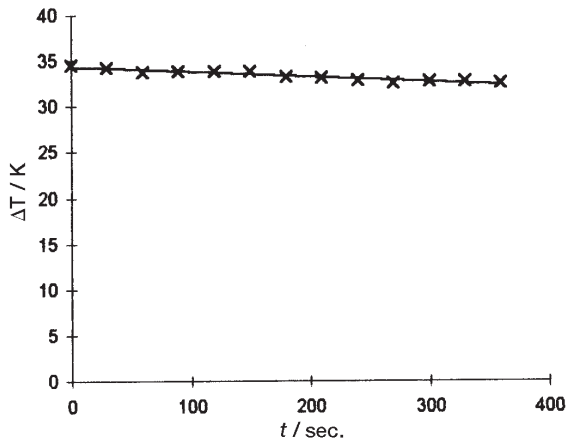

area ($A: 4.91 \cdot 10^{-4} \text{ m}^2$) and the averaged temperature on the metal rod, the heat conduction number can be calculated using Equation (1). The following result as the average values:

$\lambda_{Al} = 254 \text{ W/Km}$
 $\lambda_{Cu} = 447 \text{ W/Km}$

The literature values are:

$\lambda_{Al} = 220 \text{ W/Km}$
 $\lambda_{Cu} = 384 \text{ W/Km}$

3. At room temperature the conduction electrons in metal have a much greater mean free path than the phonons. For this reason heat conduction in metal is primarily due to the electrons.

The resulting correlation between the thermal conductivity λ and the electrical conductivity σ is established by the Wiedmann-Franz law:

$$\frac{\lambda}{\sigma} = L T \quad (8)$$

The Lorenz number L , which can be experimentally determined using Equation (8), is established by the theory of elec-

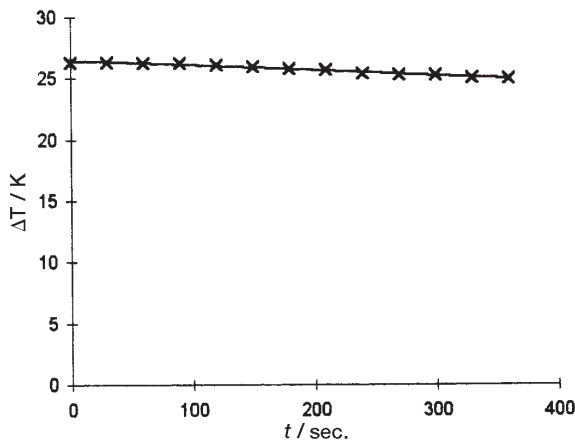
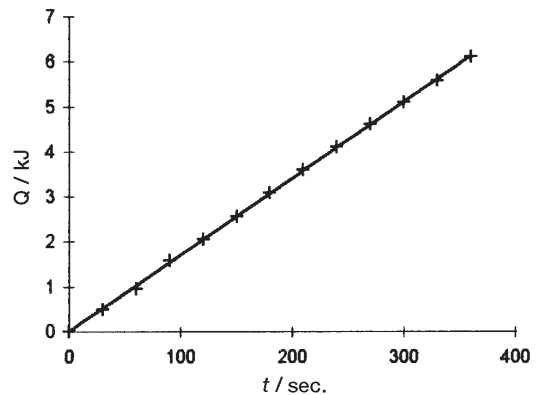

Fig. 5a: ΔT as function of time for copper.

Fig. 4b: Q as a function of time for aluminium.



tron vapour (for temperatures above the Debye temperature) to be:

$$L = \frac{\pi^2}{3} \cdot \frac{k^2}{e^2} = 2.4 \cdot 10^{-8} \frac{\text{W}\Omega}{\text{K}^2} \quad (9)$$

$k =$ Universal gas constant = $1.38 \cdot 10^{-23} \text{ J/K}$
 $e =$ Elementary unit charge = $1.602 \cdot 10^{-19} \text{ AS}$

The electrical conductivity is determined by the resistance R of the rod and its geometric dimensions ($l = 0.315 \text{ m}$, $A = 4.91 \cdot 10^{-4} \text{ m}^2$).

$$\sigma = \frac{l}{A \cdot R} \quad (10)$$

From Equation (8) The following values result for $T = 300 \text{ K}$ and the λ from the second part of the experiment.

	$R/10^{-6} \Omega$	$\sigma/10^7 (\Omega\text{m})^{-1}$	$L/10^{-8} \text{ W}\Omega\text{K}^{-2}$
Al	19.6	3.27	2.5
Cu	12.04	5.33	2.35

The Debye temperatures of copper and aluminium are 335 K and 419 K, respectively. Below the Debye temperature the ratio of the conductivity is smaller than given by Equation (8).

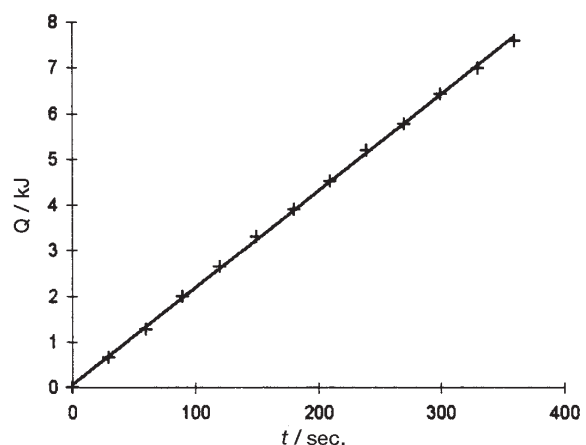

Fig. 5b: Q as function of time for copper.