

Geological Mapping 1
Academic Year 2016/2017

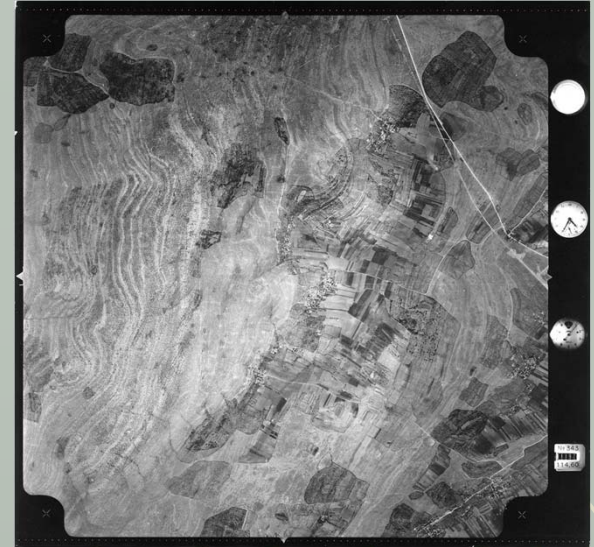

Introduction to Photogeology

Igor Vlahović

igor.vlahovic@rgn.hr



Today we will say a little about basic photogeological analysis of terrain:

- about aerial photographs, and
- stereoscopic analysis.



Photogeology

Photogeological research represents a systematic study of geological relationships by usage of photographs taken from the air.

Photogeology is used in all phases of the map production, depending how photogenic is the terrain.

In the preparatory phase on the basis of photogeology the main relationships in the study area can be assumed.

During the fieldwork geologists can check the assumptions shown in the initial photogeological map.

In the final production of the map photogeology serves to connect and complement the established geological relationships.

Aerial photographs

Aerial photographs (photograms) are pictures taken from aircraft equipped with special cameras. The camera can be set at different angles, but for geological applications almost exclusively vertical images are used. Exceptions are oblique photographs used for study of thrusts and unconformities.

When recording different types of films may be used, but the most common are panchromatic films with a yellow filter, producing high-quality grayscale images. Color photographs are used less, because of the sensitivity on the shooting conditions (especially mist), relatively low-quality color and historically higher prices, though modern digital equipment changes the game.

Each photograph contains a series of data that are placed, depending on the camera type, at various locations along its edge.



Tags for center of
the aerial
photograph



Tags for center of
the aerial
photograph

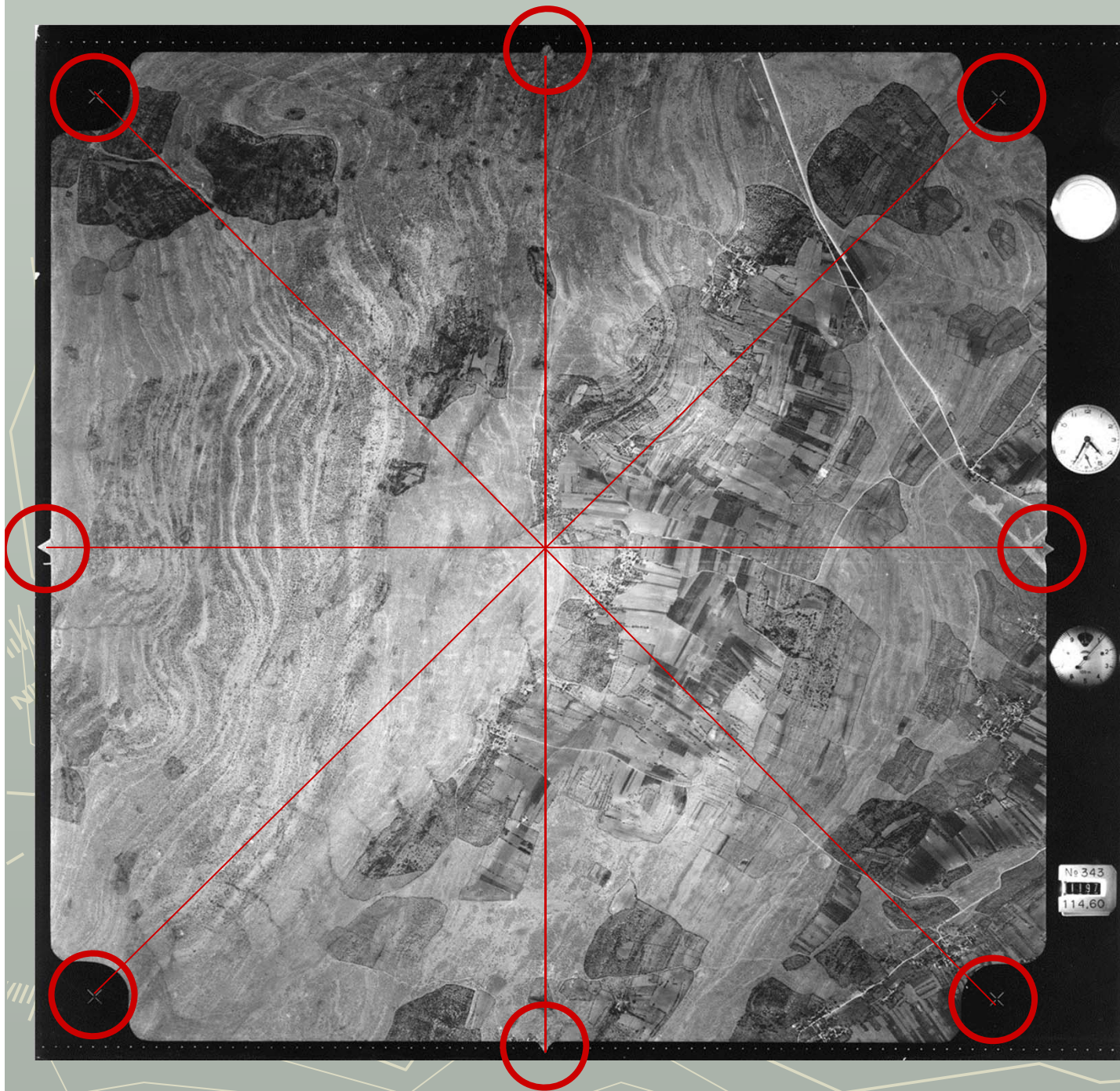

Tags for center of
the aerial
photograph

are used to find the
principal point.

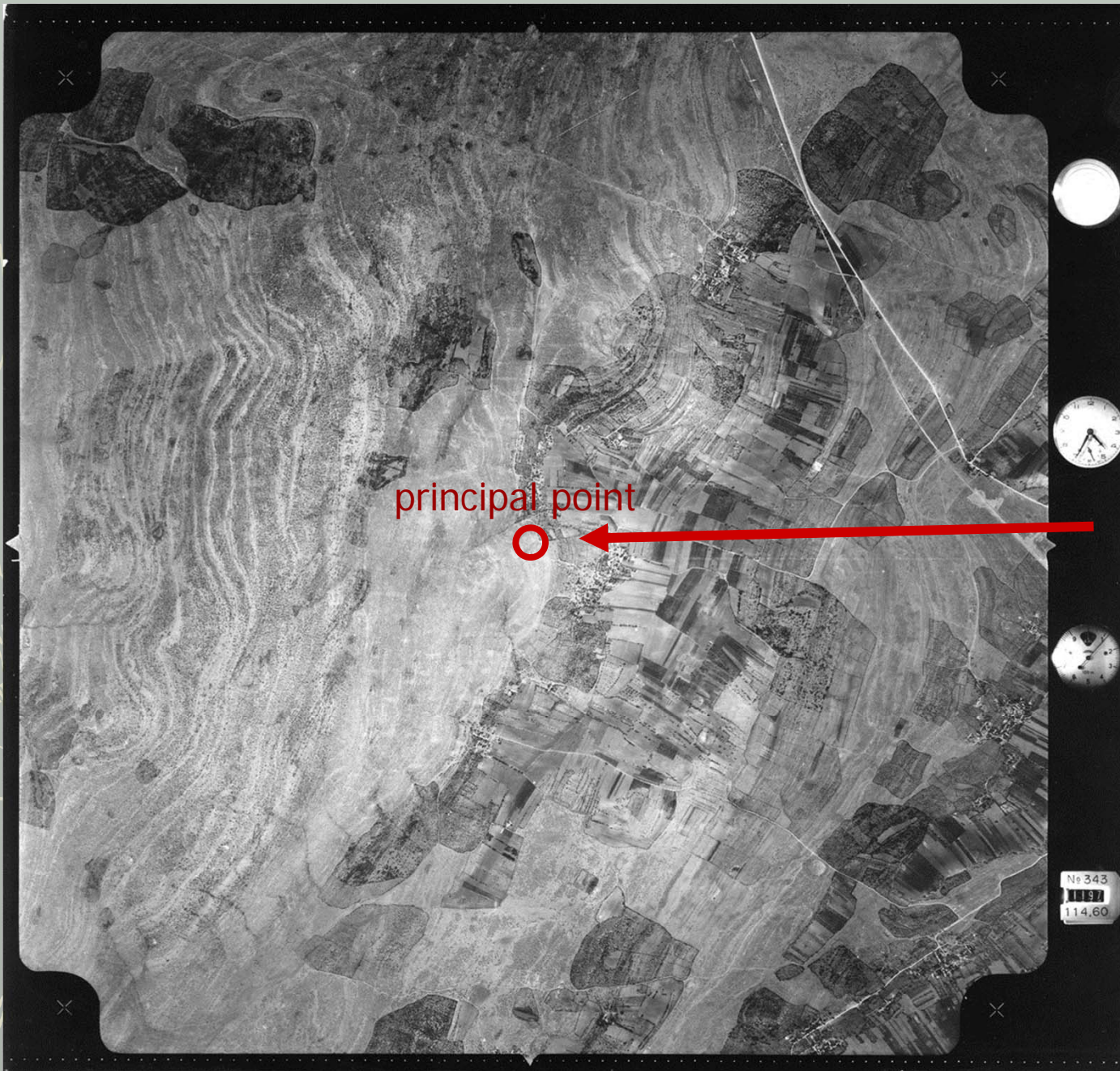

principal point

The principal point is exactly the point directly below the airplane at the moment of shooting the photograph.

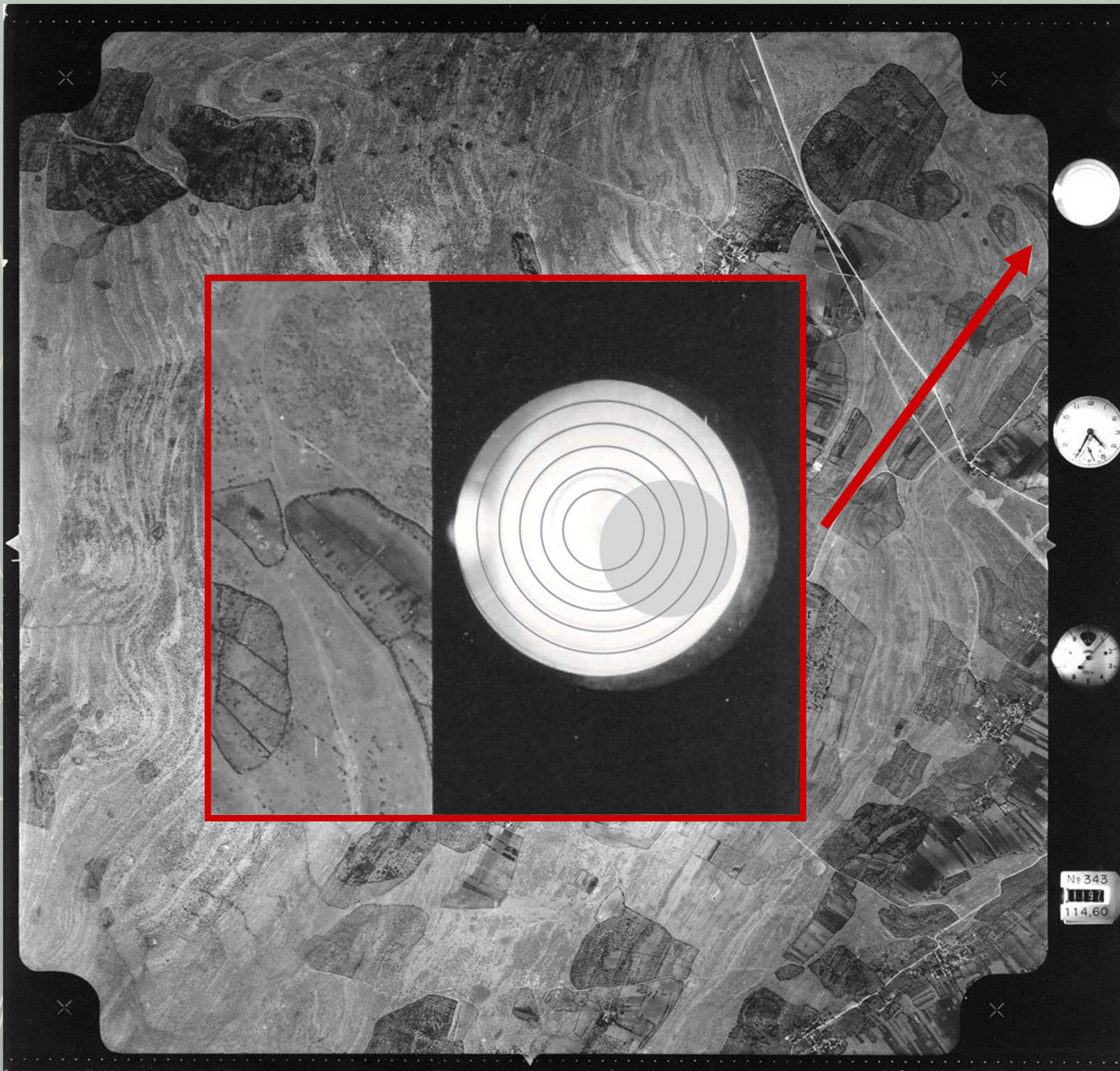

Level

shows the tilt of the camera vertical axis at the time of shooting, thus indicating possible deformation of the photograph.

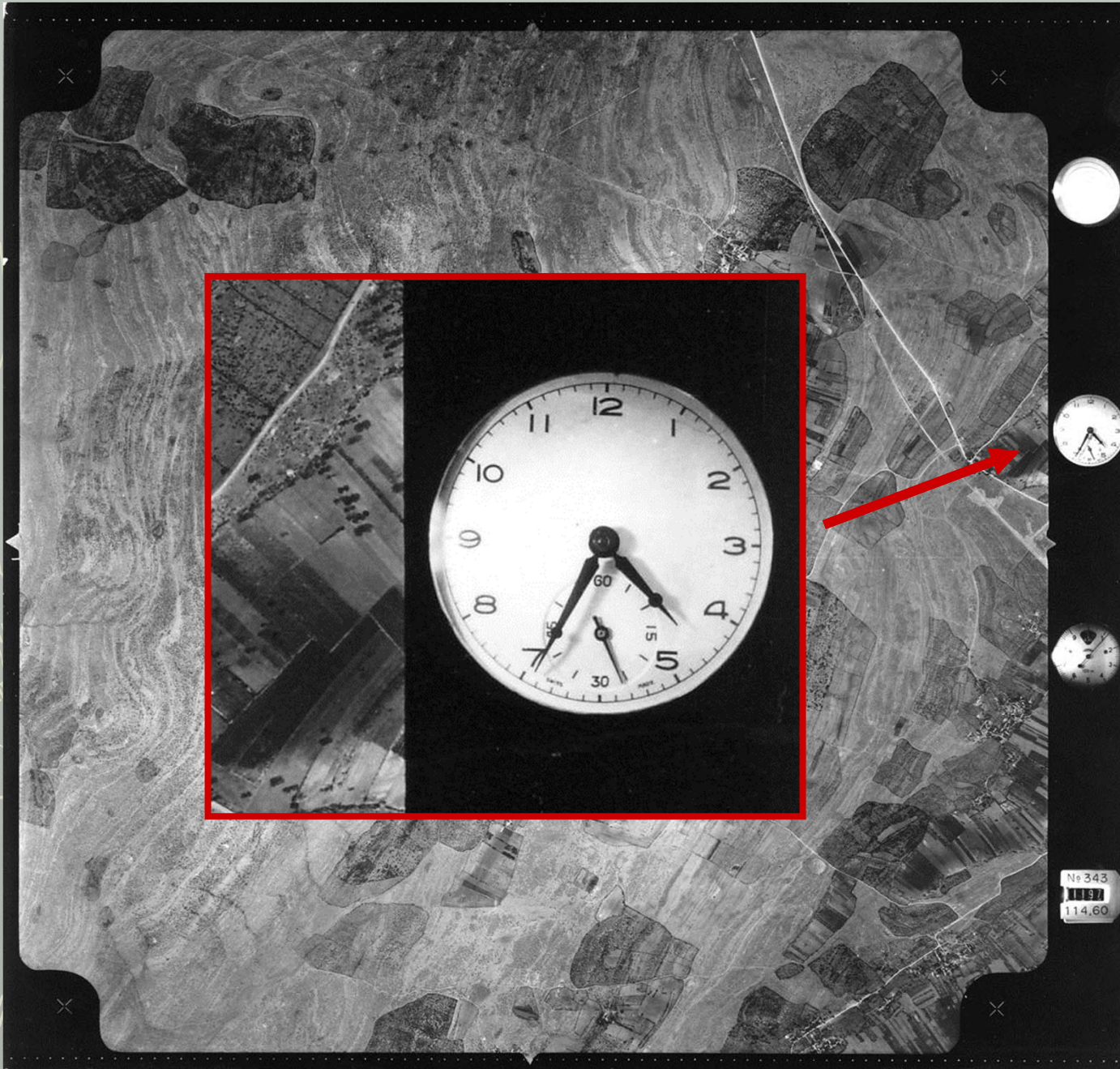

Watch shows recording time – the best time is either early morning or late afternoon, because shadows emphasize relief.

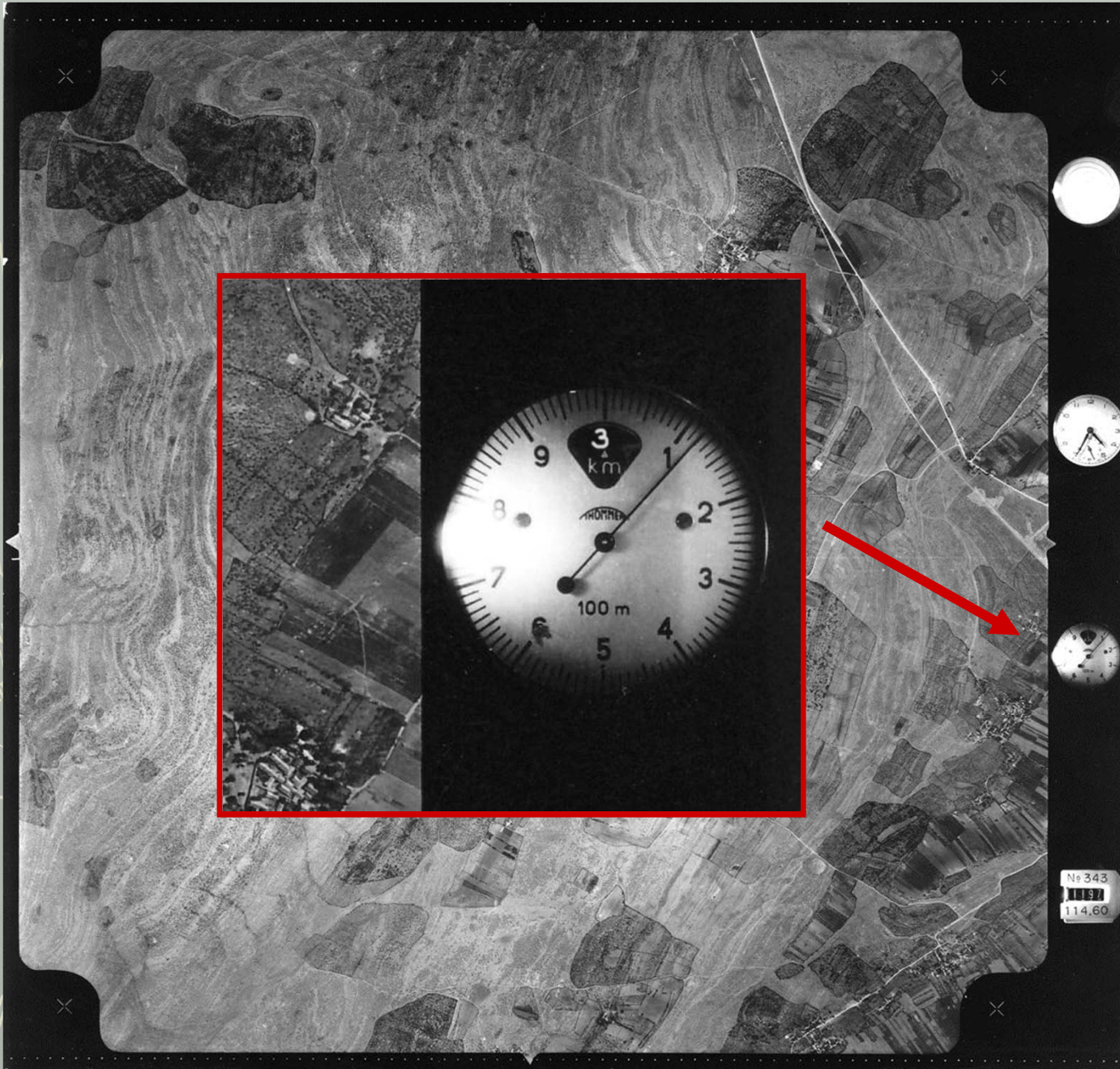

Altimeter shows the absolute altitude of the aircraft at the time of shooting.

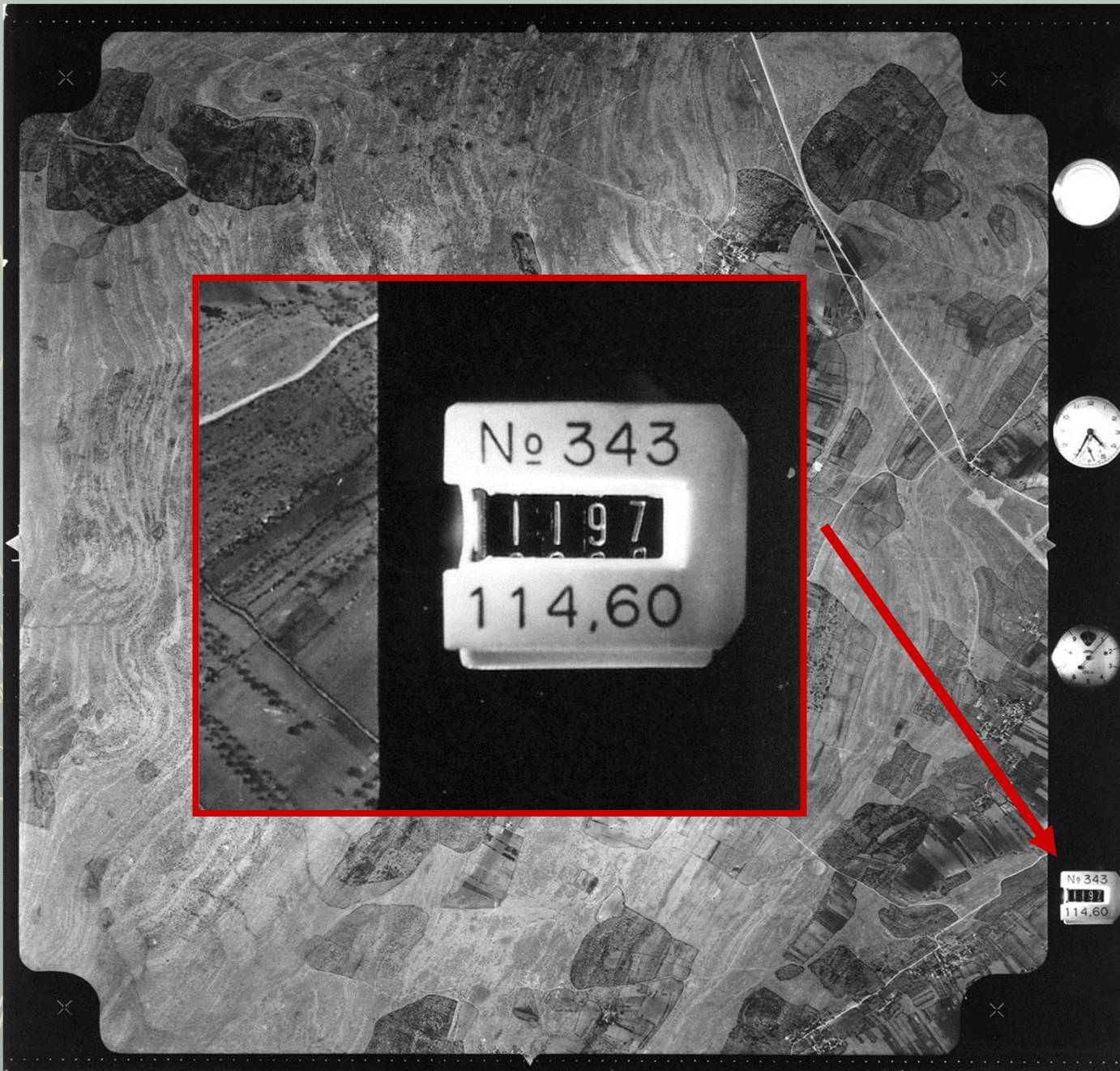

Additional data on the image are camera number, frame number and the focal length of the camera lens.

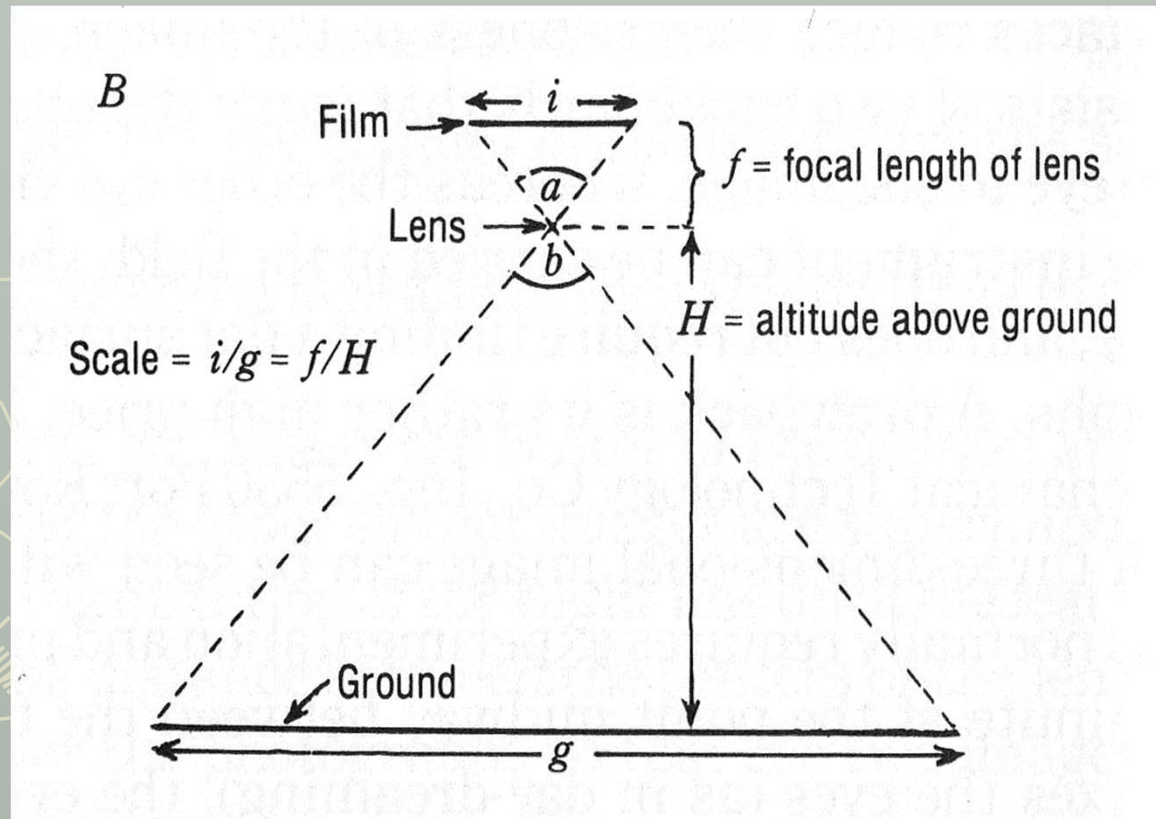

The scale of the photograph is ratio of the focal length of the camera lens and the distance from the camera to the surface of the Earth, i.e., a relative height of the aircraft at the time of shooting.

Usual scales are between 1:5,000 and 1:60,000.

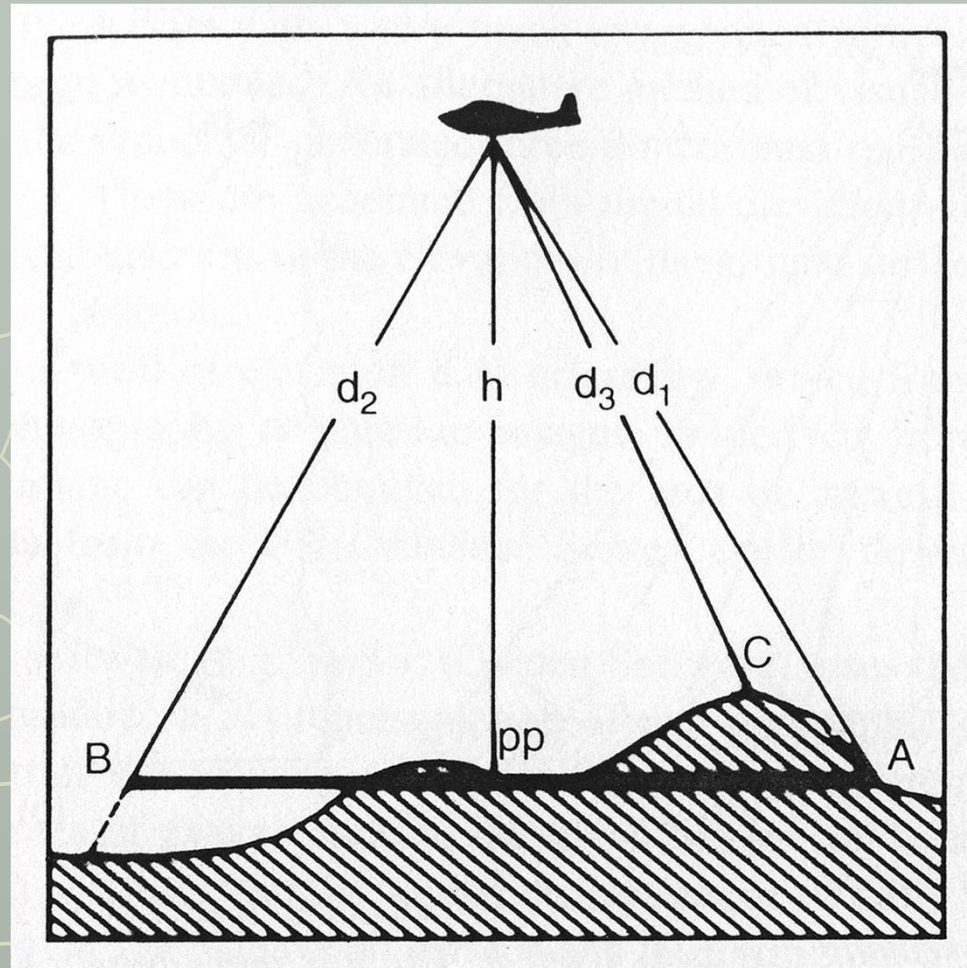

The problem is that the scale of the photograph is variable from place to place, because the top of the hill is closer to the camera than the bottom of the valley, and the centre of the photo is closer than its edge.

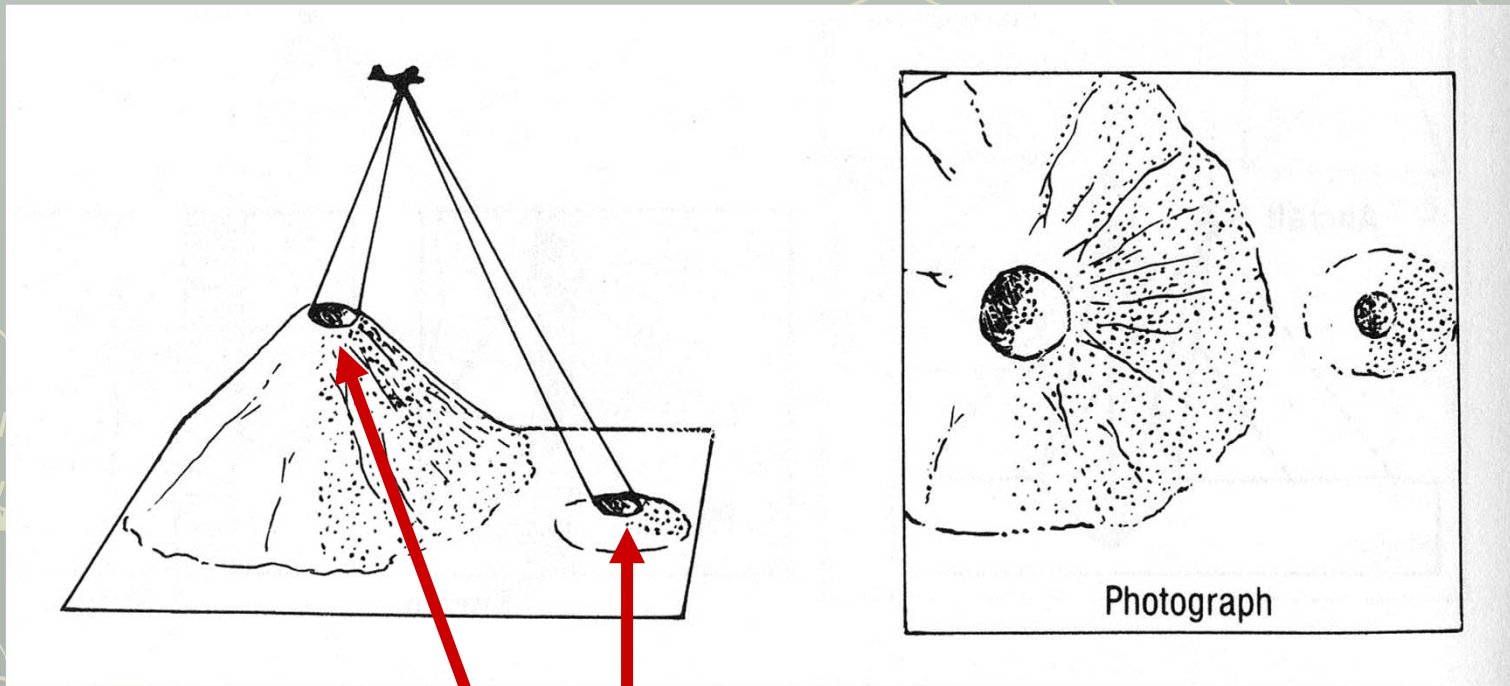

Same diameter of the volcano crater

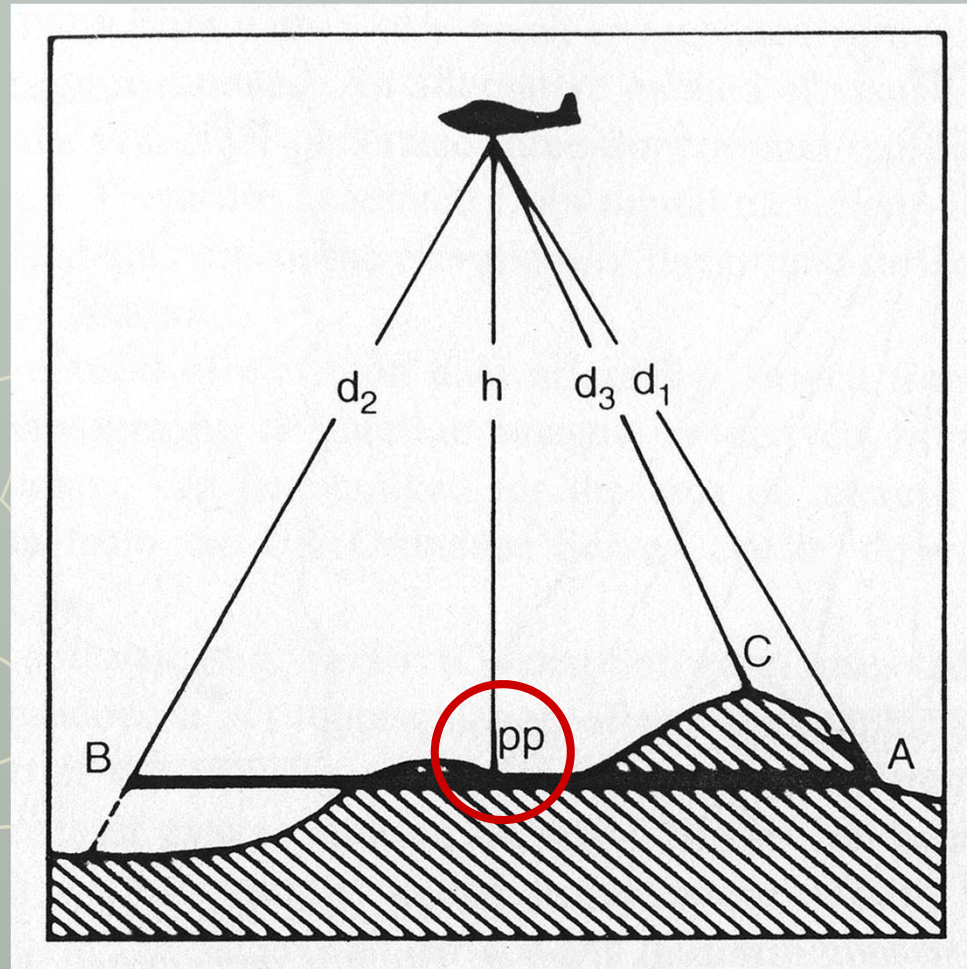

Therefore, the nominal scale of the photograph is calculated over the principal point (pp).

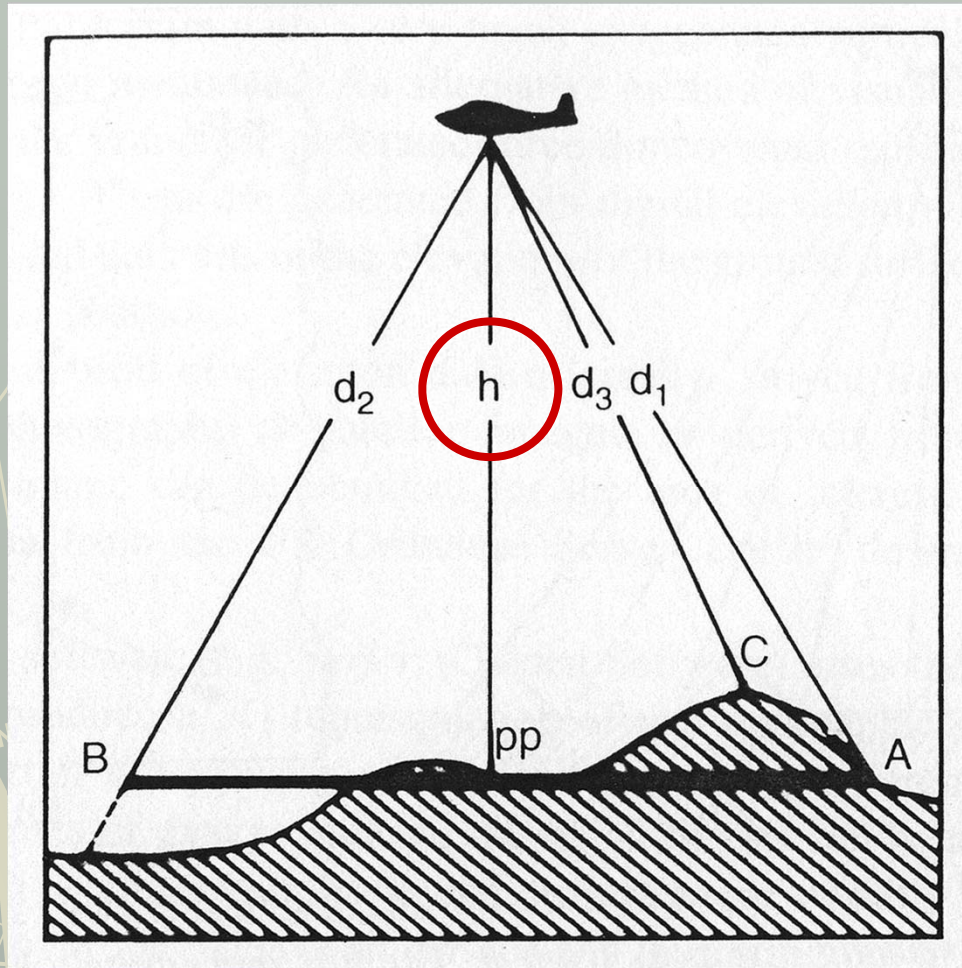

Relative aircraft elevation (h) required for the nominal scale is calculated by subtraction of the altitude displayed on photograph minus and the altitude of the principal point (as read from the topographic map), and the focal length of camera is also shown on each photograph.



Relative elevation of the aircraft in this case is 3120 m (absolute altitude read on the altimeter) minus 340 m (elevation of the principal point of the photograph as read on topographic map), i.e. 2780 m.



Focal length of camera is 114.60 mm.

Nominal scale represents a ratio between focal length of camera and relative elevation: nominal scale of this aerial photograph is $114.60 \text{ mm} / 2,780.000 \text{ mm}$, i.e. approximately 1:24258.

The background of the slide is a light green map with white contour lines. In the bottom-left corner, there is a compass rose with a yellow needle pointing towards the top-left. The compass rose has labels for 'N', 'NE', 'E', and 'SE'. There are also some other symbols like 'NW' and 'S' visible. The contour lines are irregular and jagged, representing a topographic map.

Relationship between aerial photographs and topographic maps

Unlike topographic maps produced in the orthogonal projection aerial photographs are shot in central projection, leading to deformation of the terrain in the photograph.

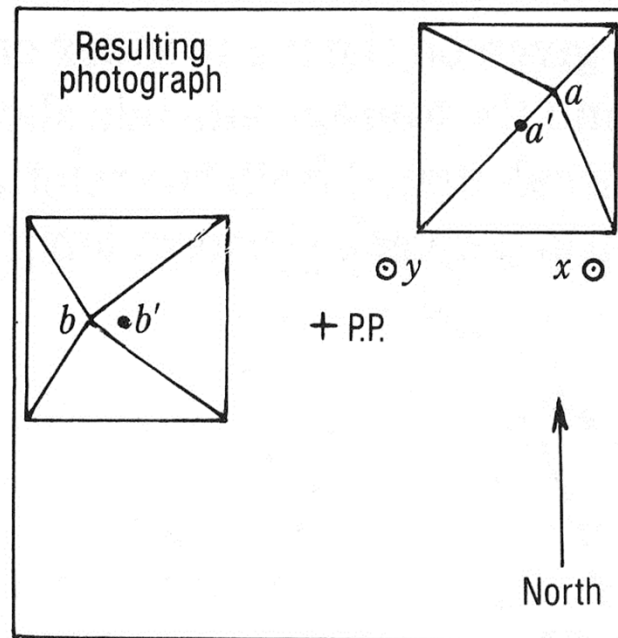
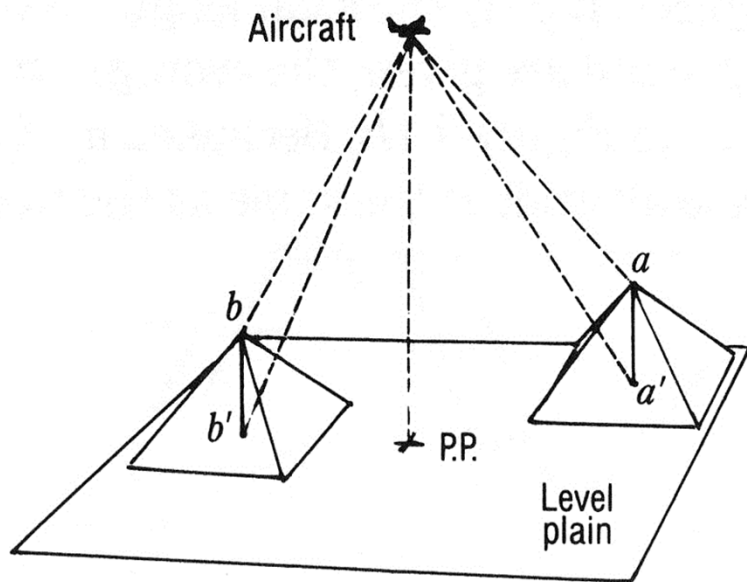

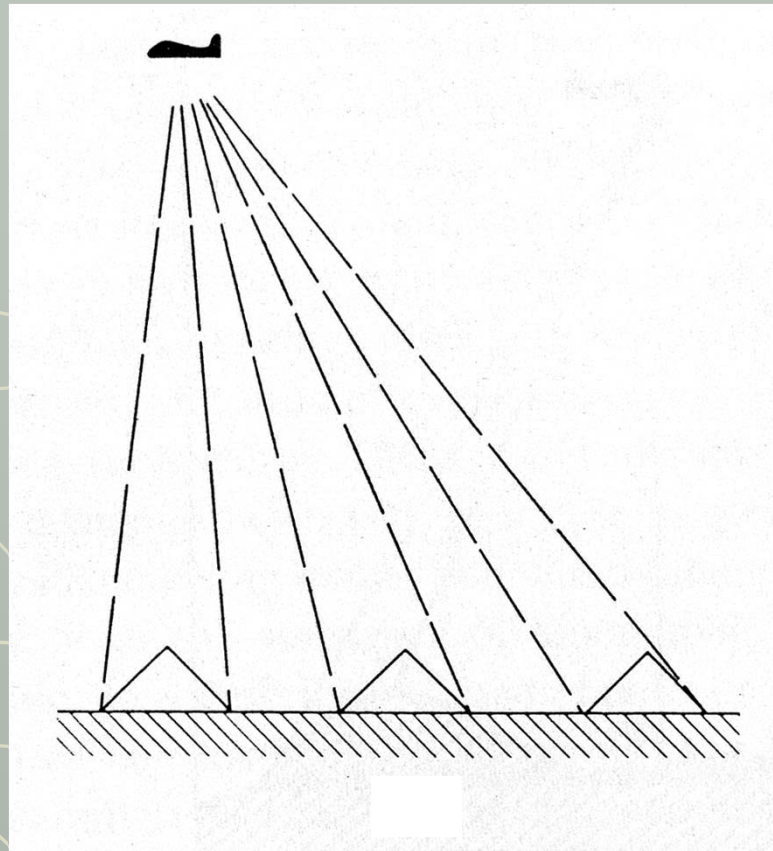

In this case, only a small part of the right side of the pyramid is visible that faces the edge of the image: the result is that it seems as if objects located at the edge of photographs are tilted from the center, i.e. the principal point.

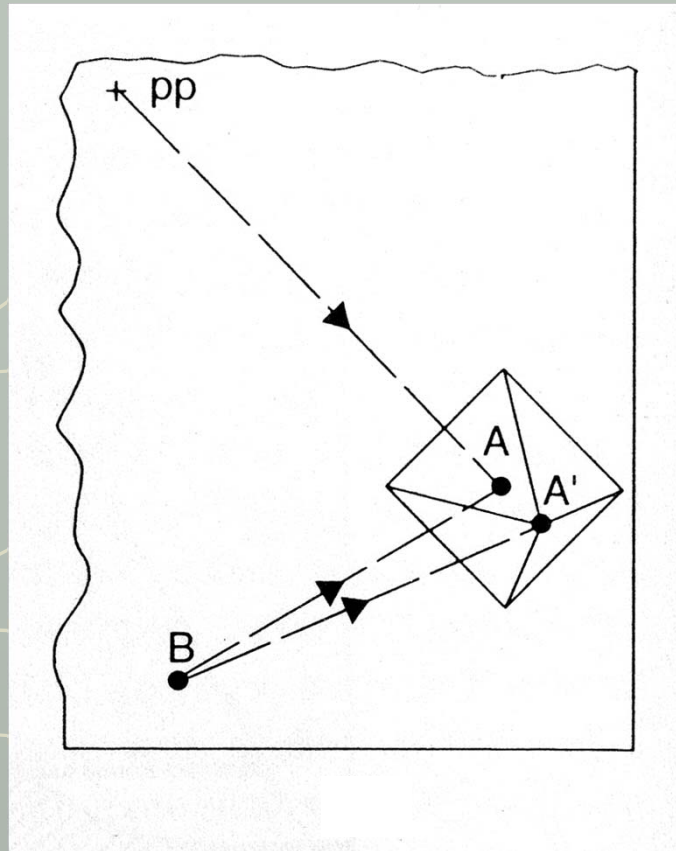

Therefore the azimuths to all higher objects other than those measured in the radial direction from the principal points are incorrect, especially closer to the edge of photographs. This bias is even more pronounced by increased height difference between points B and A'.

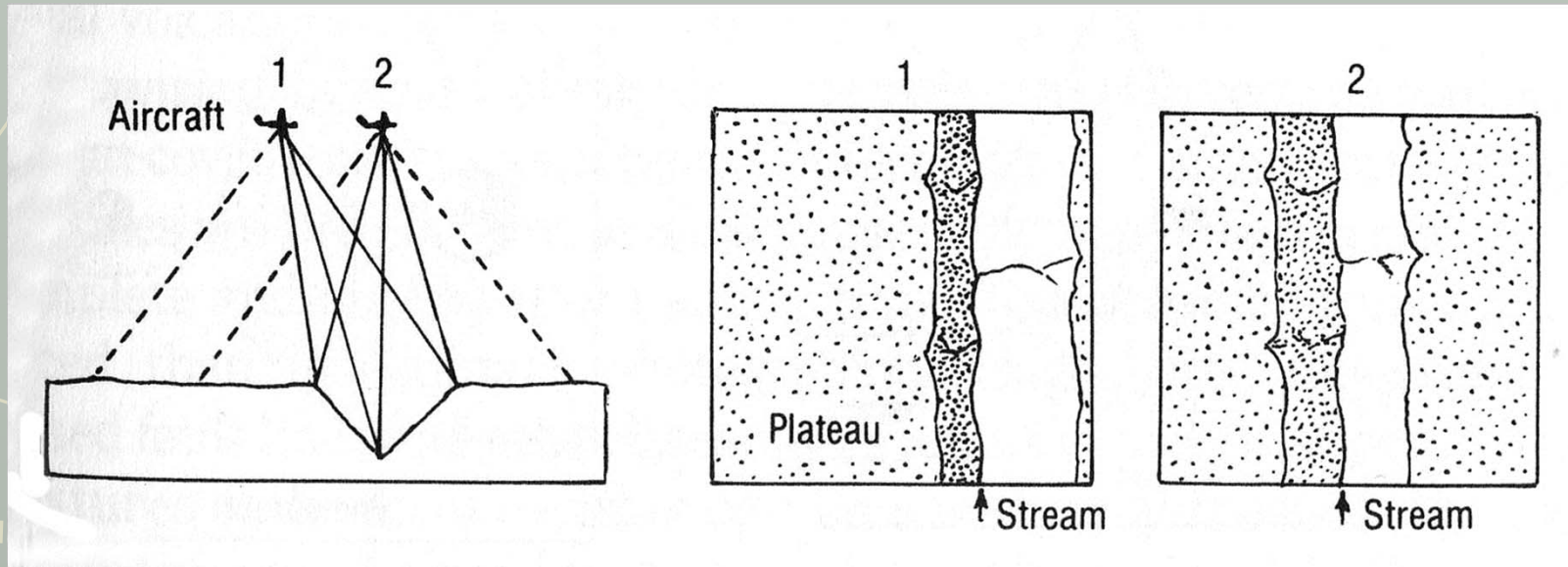

Another consequence of the central projection are sometimes significant differences in the shape or width of objects on neighboring photographs. This is particularly important, because during the photogeological studies pairs of adjacent photos are used.

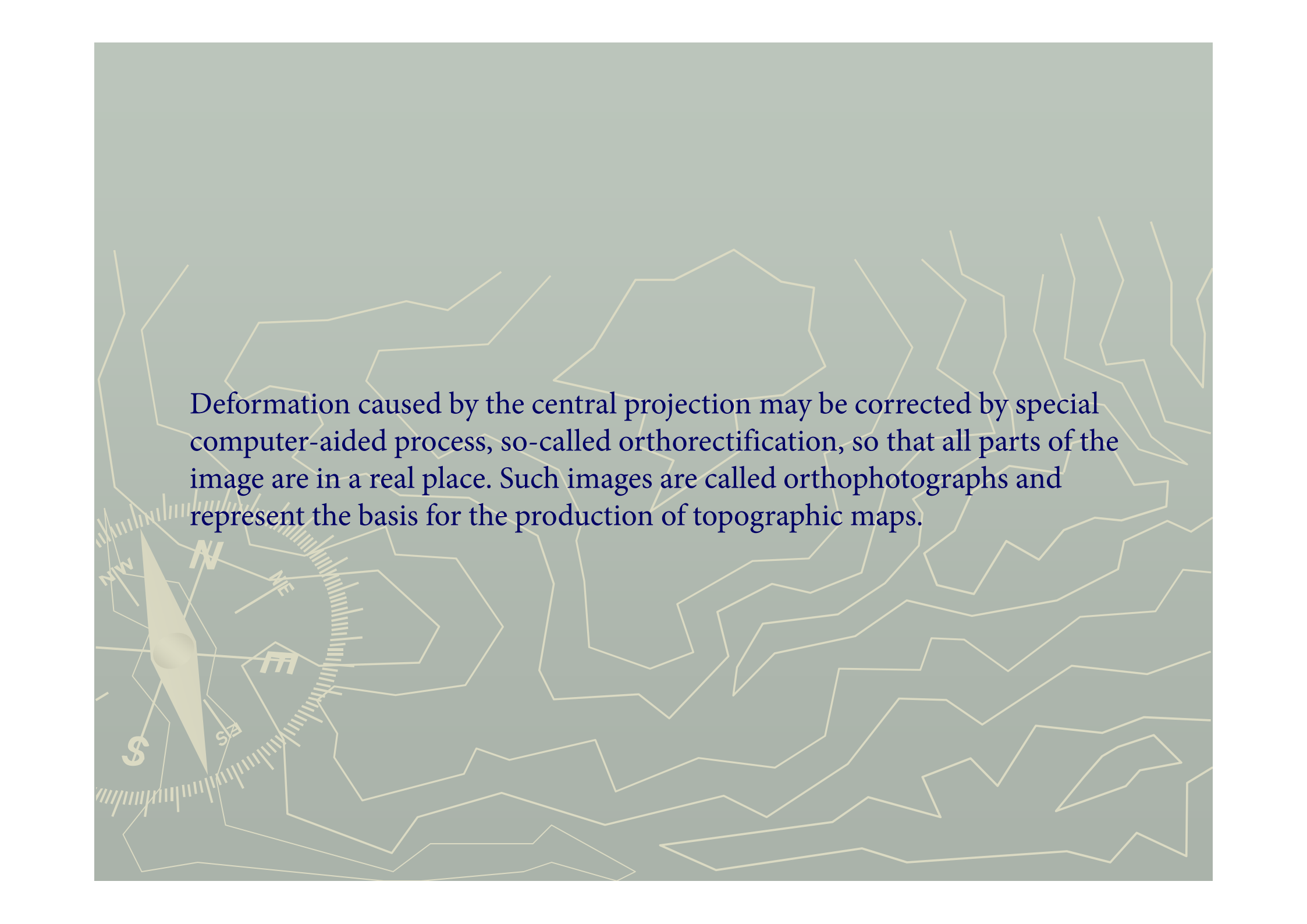
The background of the slide is a light green topographic map. It features several contour lines of varying thickness and spacing, representing different elevations. In the lower-left corner, there is a compass rose with a yellow needle pointing towards the top-left. The compass rose is marked with cardinal and ordinal directions: 'N' for North, 'NE' for Northeast, 'E' for East, 'SE' for Southeast, 'S' for South, 'SW' for Southwest, 'W' for West, and 'NW' for Northwest. The text is centered on the map.

Deformation caused by the central projection may be corrected by special computer-aided process, so-called orthorectification, so that all parts of the image are in a real place. Such images are called orthophotographs and represent the basis for the production of topographic maps.

Stereoscopy

Photogeological research is based on the study of the so-called stereopairs of images, i.e. photographs taken in sequence to form pairs that can be viewed three-dimensionally, i.e. get a sense of the depth of the area.

Human eye is actually a small camera of a very high resolution, whose lens has a focal length of about 17 mm, and can be accommodated to distances of up to 10 m. Therefore one eye can not compare the distances between objects if they are more distant than ten meters.

Our three-dimensional vision is based on the simultaneous observation by the two eyes, which are usually 55–72 mm apart, when two two-dimensional images are composed into the single 3D image in the brain. Such a difference can be seen if the angle is greater than $30''$, that is, up to about 500 m.

Stereoscopy (2)

In order to be able to observe the relief three-dimensionally every part of the field has to be photographed from the air twice, from two different points, and then each of two images seen by the eye located at the center of image projection: left image by left eye and the right image at the same time by right eye, located at its center.

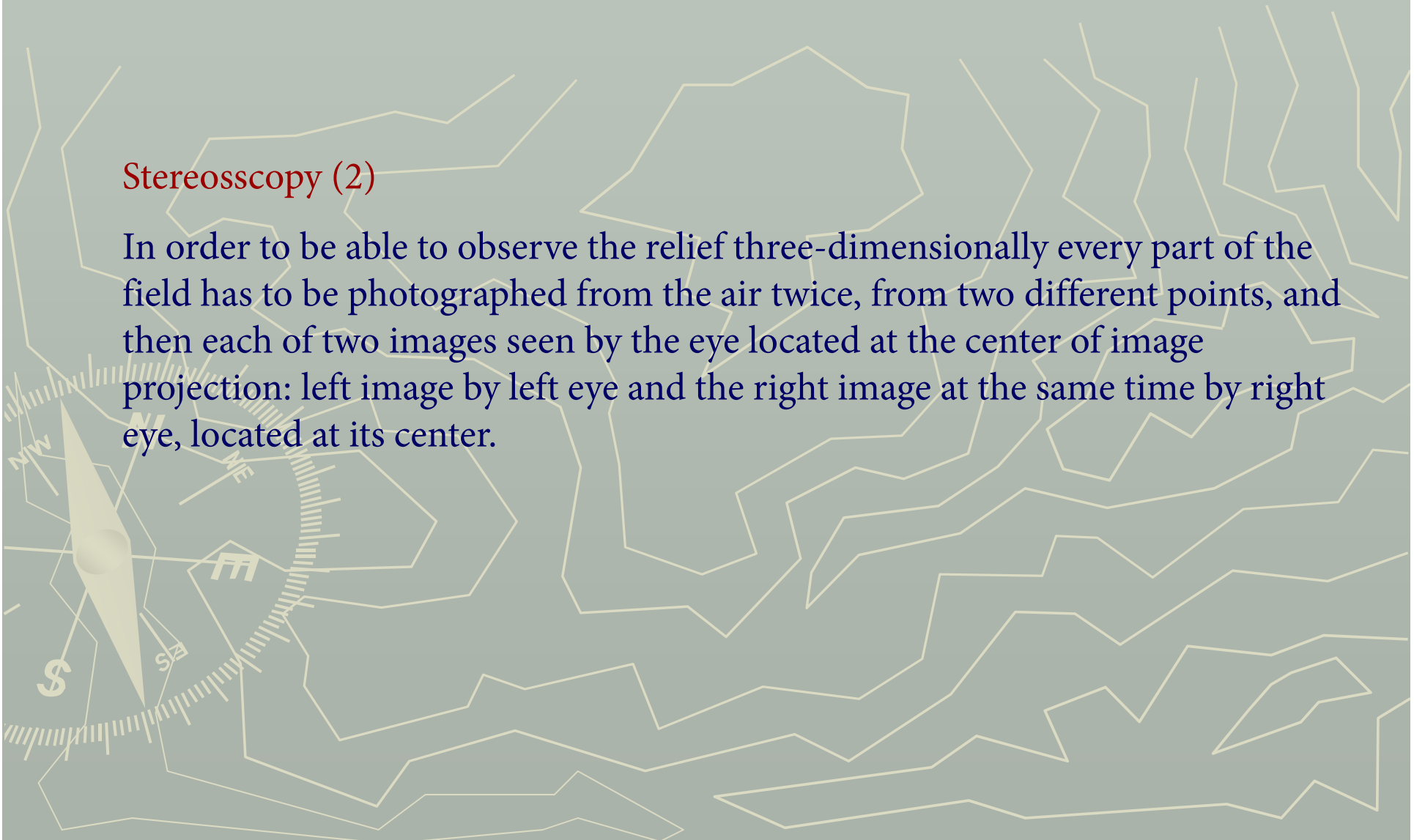

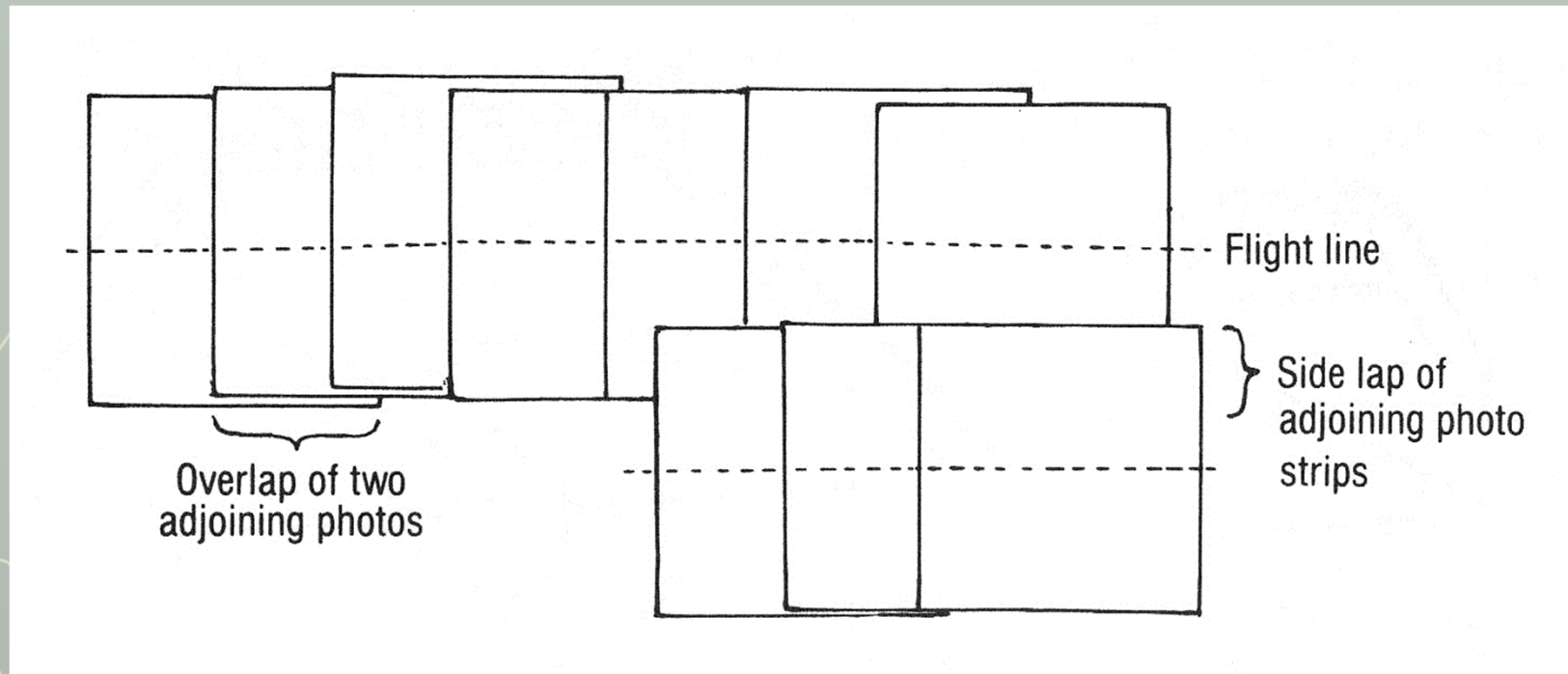

Stereoscopy (3)

Therefore aerial photographs are recorded in rows, in which two adjacent photographs typically overlap 60–75% (in lowland areas may be less, but the minimum is 50%), in order for each object on the ground to be shot twice, i.e. each two consecutive photographs make one stereopair.

Aircraft typically fly in east–west direction, and the two adjacent rows overlap around 10–25%.

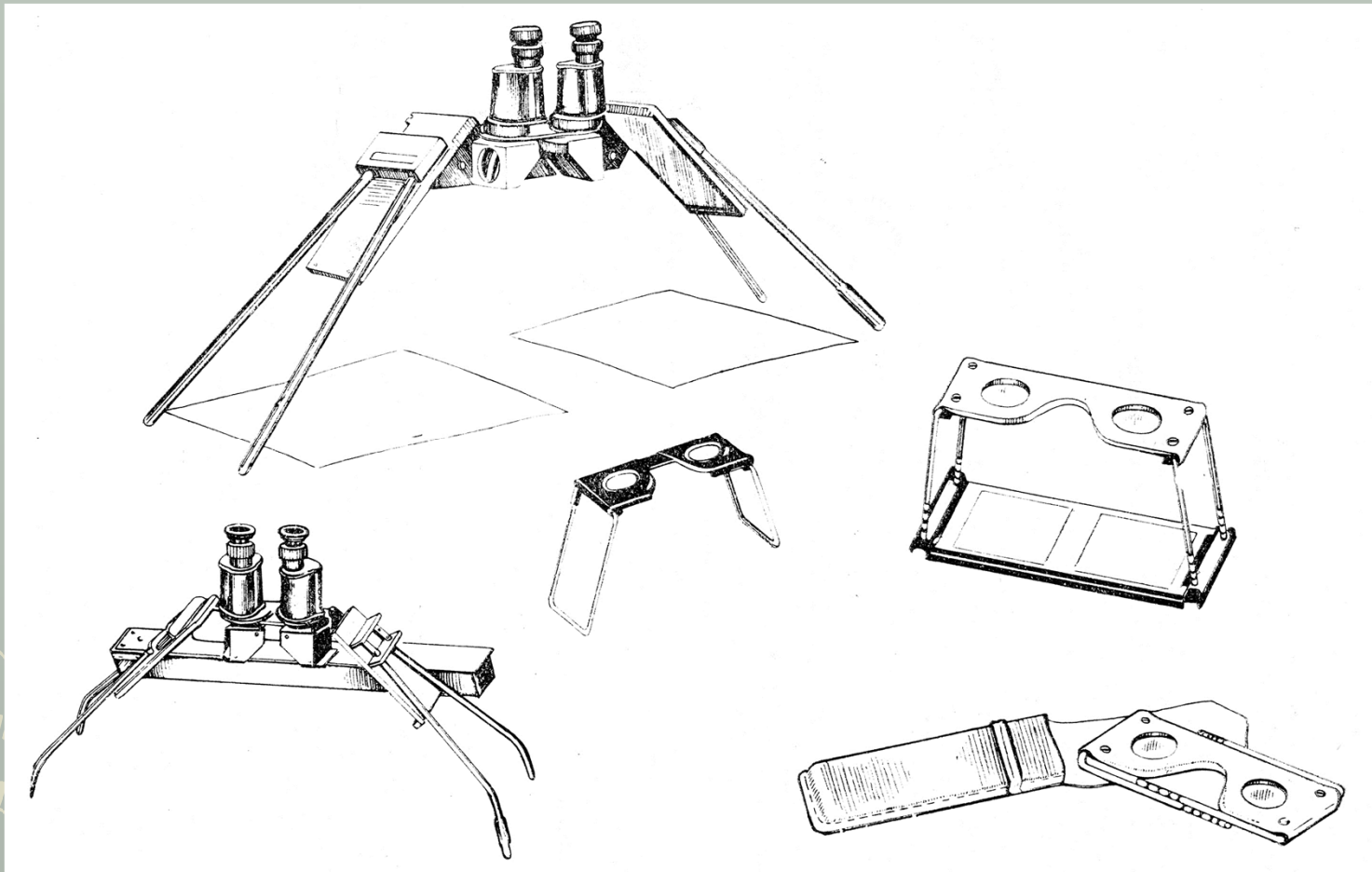

Stereoscopy (4)

Stereopairs are observed by special devices, stereoscopes, which greatly facilitate obtaining of three-dimensional images.

Commonly in use are two types of stereoscopes: a pocket and table stereoscopes (which may be reflective or prismatic).

Stereoscopy (5)

In order to get a 3D image adjoining photographs which make stereopairs should be set in the optimum position, which significantly facilitates the work, especially the long-term...

This is done by marking on each photographs principal points of adjacent two photographs, i.e. each aerial photograph should have three points marked: its principal point and two extra, auxiliary points, corresponding to principal points of the neighboring photographs.

For pocket stereoscopes separation (horizontal distance between same spots on two consecutive photograms) is approximately 6 cm, while for table stereoscopes it is 20–25 cm).

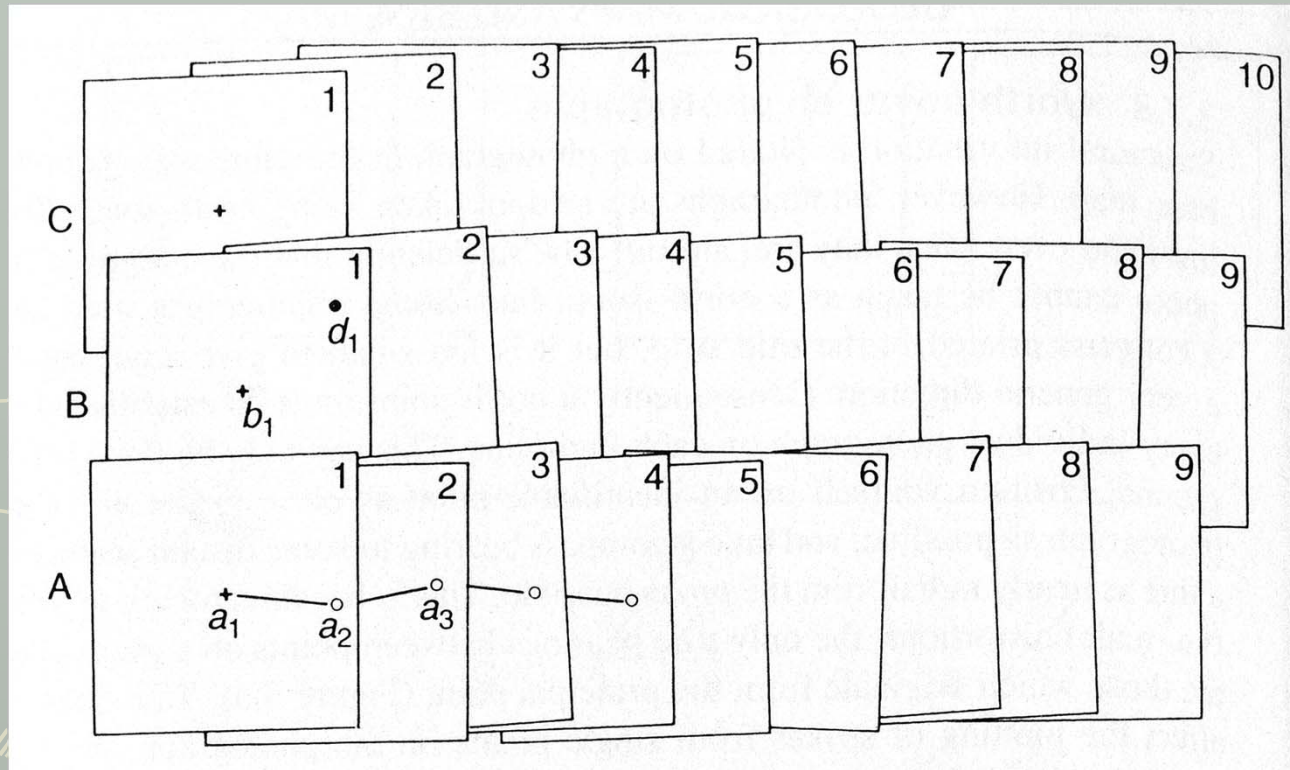













Stereoscopy (6)

By connecting the principal and auxiliary points so-called base line is drawn, which represents the exact line of flight of the aircraft during the shooting.

When with the help of the stereoscope principal and minor point of adjacent photographs are coinciding the best orientation is achieved, which reduces eye fatigue during photogeological processing.

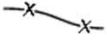





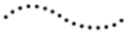
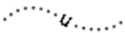

Photogeological map symbols

4.1.1 Morphological Features

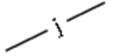
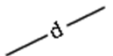
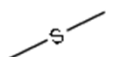
	Outer edge of terrace or declivity (teeth away from edge) The letters "a" or "e" may be used to distinguish accumulation or erosion terraces.
	Landslide
	Scree slope
	Karst solution hollows (sink-holes, uvalas, poljes, dolines)
	Volcanic cone
	Generally depressed area, negative aspect relative to surroundings
	Generally elevated area, positive aspect relative to surroundings
	Abrupt change of relief, e.g. foot of hills
	Major divide or crestline
	Minor divide or crestline
	Linear feature of unknown origin
	Wind direction
	Direction of morphological dip (dip of surface, plain, terrace etc.) Use symbols from 4.1.2, combined with letter "M", for added precision, if desired.

Photogeological map symbols (2)

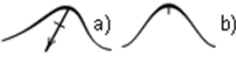
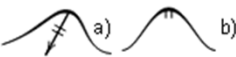
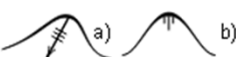
4.1.2 Geological Features (see also 4.7 Structural Geology)

	Lithostratigraphical boundary
	Unconformity; the use of heavier dots for unconformities is optional
	Edge of stratum, whether expressed as scarp, scarplet or otherwise deduced
	Joint
	Dike
	Strike line (general symbol)
	Horizontal bedding
	Subhorizontal ($< 2^\circ$) bedding (slight southerly dip)
	Outcropping layer with dip slope in general The arrow should be extended over the full length of the visible dip slope.
	Gentle dip slope (2° - 5°)
	Moderate dip slope (6° - 20°)
	Steep dip slope ($>20^\circ$)
	Vertical bed

Symbols without arrows: b) may be used when space problems prohibit the arrow symbology of a)

Photogeological map symbols (3)

Regional or large-scale features may be distinguished from local or minor features by using open vs. closed symbology, e.g.:



Direction of dip, regional



Direction of dip, local



Axis of major regional high, culmination, geanticline

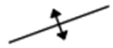

Axis of high, anticline



Thanks for your attention, but before the end...

Photogeologist in shrink's ordination...



... and couple of links for today

[Advanced Photogeology Lecture Notes](#)

[Principles of Remote Sensing](#)

<http://www.google.com/earth/>

[Photogeologic Map of the Moon](#)

[50 Interesting Facts About the Earth](#)

